

INSTALLATION & OPERATING MANUAL  
G9 High Efficiency Gas Heater

# A GUIDE TO YOUR GAS HEATER

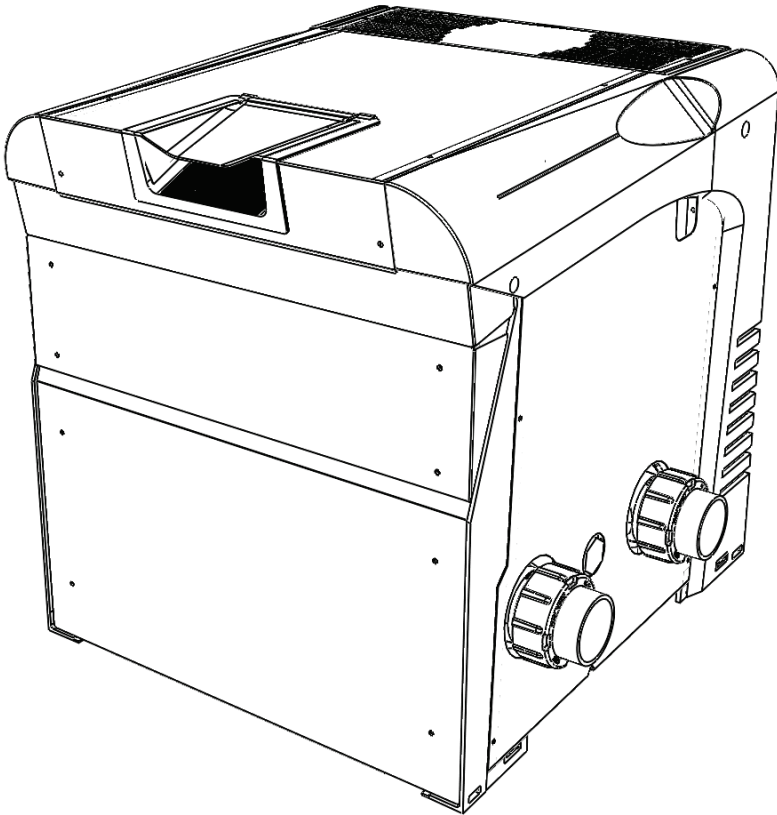

# CONGRATULATIONS ON YOUR PURCHASE OF THIS PRODUCT.

THIS MANUAL HAS BEEN CAREFULLY DEVELOPED TO GIVE YOU ALL THE INFORMATION YOU NEED TO GET THE BEST VALUE FROM YOUR PURCHASE.

It is important that you read through the manual to identify the key areas you need to understand, particularly the following:

- Health and Safety Concerns
- Installation requirements
- How to operate the major features of the unit
- The importance of maintenance
- If you have a problem, what to trouble shoot before you contact your professional
- Finally, your entitlements under your product warranty.

Insnrng have developed their product to provide you with the ultimate experience and are sure you will be delighted with your purchase.

Please note: This equipment must be installed in a location that allows for regular maintenance and service by the pool owner and service technicians. Insnrng will not put service technicians at risk of injury by servicing difficult to access appliances.

# THE IMPORTANT BITS

03

SECTION 1:

**We care about your safety**

Local Code

Safety Instructions

Carbon Monoxide

Important Tips for Hot Tubs & Spas

11

SECTION 2:

**We want you to be delighted**

Location & Dimensions

Indoor & Outdoor Installations

Gas Connections

Water Connections

Electrical Connections

39

SECTION 3:

**Now to Have some Fun**

Operation

46

SECTION 4:

**Oops, something not right?**

Maintenance

Winter Operation

Troubleshooting

Replacement Parts

Warranty

## SECTION 1

# WE CARE ABOUT YOUR SAFETY



## IMPORTANT WARNINGS

Please read this manual carefully **BEFORE** installing, operating or servicing the Gas Heater.

If these instructions are not followed exactly, a fire or explosion may result, causing property damage, personal injury, or death.

This Appliance is not intended for use by young children or infirm persons without supervision. Please ensure that young children are supervised so that they do not play with the appliance.

# LOCAL CODES

## AUSTRALIA

Must be installed in accordance with the installation instructions, local gas fitting regulations, Standards Australia Installation Code AS/NZ 5601 and any other relevant statutory authorities.

## NOTICE TO INSTALLERS

This appliance must be installed by an authorized person.

This appliance must be installed in accordance with the installation instruction, local gas fitting regulations, any local regulatory standards and any other relevant statutory authorities.

Refer to date plate for details of gas type, gas consumption and burner pressure.

This product must be installed and serviced by a contractor who is licensed and qualified in pool equipment by the jurisdiction in which the product will be installed where such state or local requirements exists. In the event no such state or local requirement exists, the installer or maintainer must be a professional with sufficient experience in pool equipment installation and maintenance so that all the instructions in this manual can be followed exactly.

Electrical maintenance and repairs of this equipment must only be done by qualified persons in accordance with national and local regulations.

# SAFETY INSTRUCTIONS

Risk of fire or explosion from incorrect fuel use or faulty fuel conversion.

Do not try to run a heater set up for natural gas on propane gas or vice versa. Only qualified service technicians should attempt to convert heater from one fuel to the other. Do not attempt to alter the rated input or type of gas by changing the orifice. If it is necessary to convert to a different type of gas, discuss with your Insrg supplier and purchase the appropriate conversion kits. Serious malfunction of the burner can occur which may result in loss of life. Any additions, changes, or conversions required in order for the appliance to satisfactorily meet the application needs must be made by a qualified professional using approved parts. The heater is available for use with natural gas or LP (propane) gas only. It is not designed to operate with any other fuels. Refer to the nameplate for the type of gas the heater is equipped to use.

Risk of fire or explosion from flammable vapors.

Do not store gasoline, cleaning fluids, varnishes, paints, or other volatile flammable liquids near heater or in the same room with heater.

Risk of explosion if unit is installed near propane gas storage.

Propane (LP) gas is heavier than air. Consult local codes and fire protection authorities about specific installation requirements and restrictions. Locate the heater away from propane gas storage and filling equipment as specified by the Standard for the Storage and Handling of Liquefied Petroleum Gases, CAN/CSA B149.2 (latest edition) or ANSI/NFPA 58 (latest edition).

Risk of fire, carbon monoxide poisoning, or asphyxiation if exhaust venting system leaks. Only qualified service technicians should attempt to service the heater, as leakage of exhaust products or flammable gas may result from incorrect servicing.

Risk of asphyxiation if exhaust is not correctly vented. Follow venting instructions exactly when installing heater. Do not use a draft hood with this heater, as the exhaust is under pressure from the burner blower and a draft hood will allow exhaust fumes to blow into the room housing the heater. The heater is supplied with an integral venting system for outdoor installation. Use the specified venting, and only the specified venting, when heater is installed in an enclosure or indoors.

Wiring errors can cause improper and dangerous operation and can also destroy the control board. Label all wires prior to disconnection when servicing controls.

Connection in Australia is by supplied 3 Pin, 10 Amp Plug and Lead only. Verify proper operation after servicing.

Ensure wiring into heater is properly restrained and not touching hot surfaces.

Do not allow children to play on or around heater or associated equipment. Never allow children to use the pool or spa without adult supervision.

Read and follow other safety information contained in this manual prior to operating this pool heater.

# CARBON MONOXIDE

Improper installation or maintenance can result in carbon monoxide in flue gases, this can cause nausea or asphyxiation which could result in severe injury or death.

For indoor installations, it is highly recommend the installation of suitable Carbon Monoxide detectors in the vicinity of this appliance and in any adjacent occupied spaces as an additional measure of safety.

Do NOT INSTALL in a plant room, basement or any interior unless a CONDENSATE PUMP is fitted to the Heater and drain tube terminated outside.

## WHAT TO DO IF YOU SMELL GAS!

- Immediately switch off main gas supply
- Do not try to light any appliance
- Do not touch any electrical switch
- Do not use any phone in your building
- Immediately call your gas supplier from a neighbor's phone. Follow the gas supplier's instructions.
- If you cannot reach your gas supplier, call the fire department.

# IMPORTANT TIPS FOR HOT TUB & SPA INSTALLATIONS:

The following “Safety Rules for Hot Tubs,” recommended by the U.S. Consumer Product Safety Commission, should be observed when using the spa. Consult heater operation and installation instructions for water temperature guidelines before setting temperature:

- Spa or hot tub water temperature should never exceed 104°F (40°C). One hundred degrees Fahrenheit (100°F[38°C]) is considered safe for a healthy adult. Special caution is recommended for young children.
- The drinking of alcoholic beverages before or during spa or hot tub use can cause drowsiness which could lead to unconsciousness, and subsequently result in drowning.
- Pregnant women take note! Soaking in water above 102°F(38.5°C) can cause fetal damage during the first three (3) months of pregnancy (which could result in the birth of brain-damaged or deformed child). If pregnant women are going to use a spa or hot tub, they should make sure the water temperature is below 100°F (38°C) maximum.
- The water temperature should always be checked with an accurate thermometer before entering a spa or hot tub. Temperature controls may vary by as much as 1°F/ 1°C.

- Person with a medical history of heart disease, diabetes, circulatory or blood pressure problems should consult their physician before using a hot tub or spa.
- Person taking any medication which induces drowsiness (e.g., tranquilizers, antihistamines, or anticoagulants) should not use spas or hot tubs.
- Prolonged immersion in hot water can induce hyperthermia.
- Hyperthermia occurs when the internal body temperature reaches a level of several degrees above the normal body temperature of 98.6°F (37°C). Symptoms include dizziness, fainting, drowsiness, lethargy, and an increase in the internal body temperature.

The effects of hyperthermia include:

- Lack of awareness of impending hazard
- Failure to perceive heat
- Failure to recognize need to leave spa
- Physical inability to leave spa
- Fetal Damage in pregnant women
- Unconsciousness resulting in a danger of drowning

## SECTION 2

WE WANT YOU TO BE  
DELIGHTED WITH YOUR  
PURCHASE, CORRECT  
INSTALLATION WILL PROLONG  
LIFE AND MAXIMISE THE  
PERFORMANCE OF THIS UNIT.

The following section will outline how to install your heater to get the best results. To operate correctly, your Gas Heater needs a reliable supply of Gas, Water and Air.

By adhering to the following instructions, you will ensure the best combination.

Insnrng highly recommend the use of qualified service technicians to ensure the best performance as well as the health and safety of your loved ones.

## FOLLOW STEP BY STEP FOR THE BEST OUTCOME:

- 
- LOCATION & DIMENSIONS
  - CLEARANCES
  - OUTDOOR INSTALLATIONS
  - INDOOR INSTALLATIONS - VENTING REQUIREMENTS
  - GAS CONNECTIONS
  - WATER CONNECTIONS
  - BELOW POOL WATER INSTALLATIONS
  - WATER CHEMISTRY
  - ELECTRICAL CONNECTIONS

# LOCATION OF HEATER

PLAN THE POSITION OF THE HEATER SO THAT IT WILL BE:

1. Free of water, flooding and sprinklers. Avoid installation in sumps, below roof lines without gutters, or at the bottom of a run off
2. On a stable fireproof base that does not leave the heater suspended by pipework or electrical connections, allow movement through vibration and ensure no strain is put on connections or other equipment
3. Is accessible for disconnection and service
4. Within reach of the power supply
5. Complies with these instructions and all local codes and regulations



DO NOT STORE OR USE GASOLINE OR OTHER FLAMMABLE VAPORS AND LIQUID IN THE VICINITY OF THIS OR ANY OTHER APPLIANCE.

# DIMENSIONS

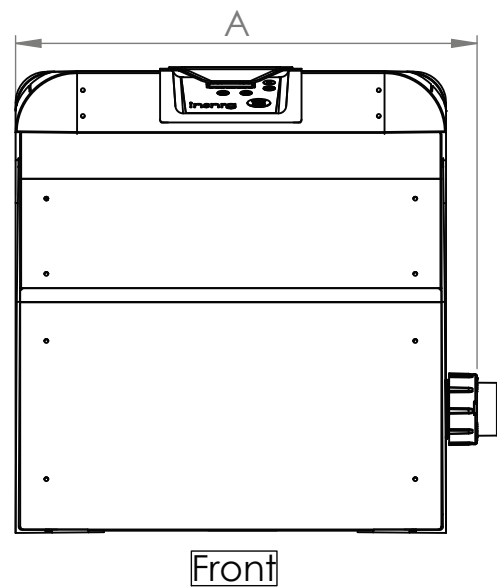
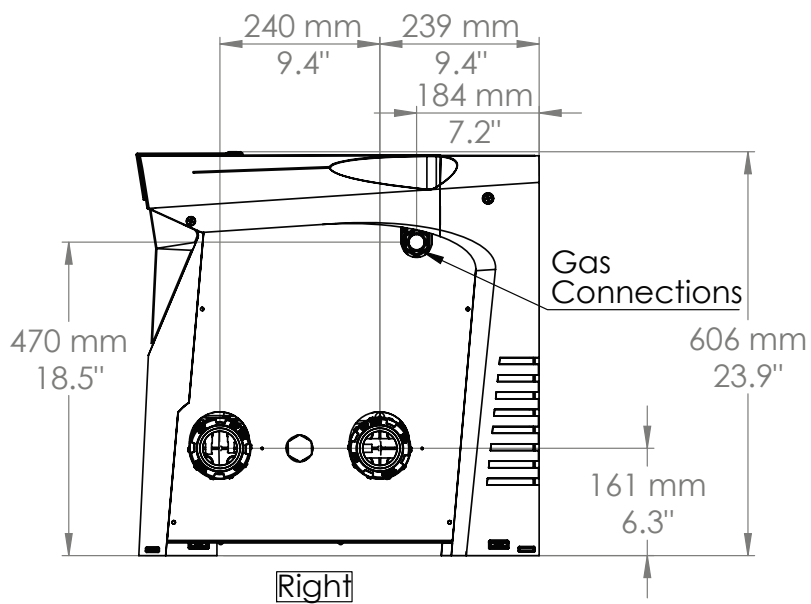
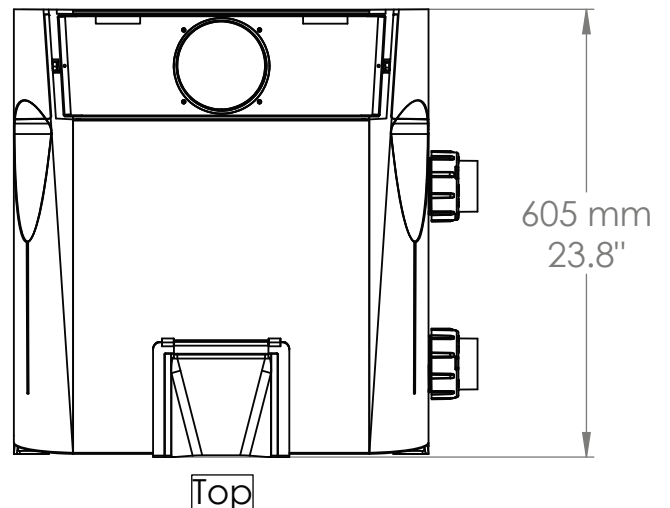
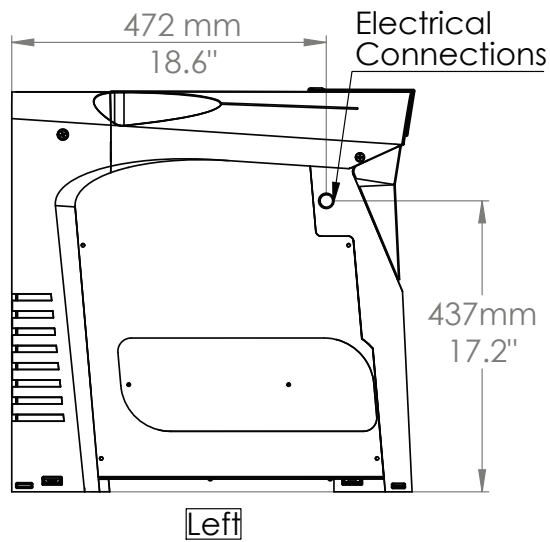

HEATER WIDTH "A"		
MODEL	(mm)	(in)
GI 160	495	19.5
GI 265	605	23.8
GI 420	765	30.1



# CLEARANCES

The heater must be installed in a location that allows clearances for maintenance and inspection. Minimum distances from combustible surfaces must also be maintained. All criteria given in the following sections reflect minimum clearances as stated in the national standards. However, each installation must also be evaluated, taking into account prevailing local conditions such as wind speed and direction, proximity and height of obstructions that may block ventilation, and proximity to public access areas.

## SERVICE CLEARANCE:

A minimum of 500mm is required from the Front and 1000mm from the Top Panels for any service requirements.

## COMBUSTIBLE SURFACES:

Each heater face requires a 150mm (6") clearance from combustible surfaces.

Although it is not advisable, the heater base can be placed on a combustible surface for operation.

However, do not install the heater on carpet.

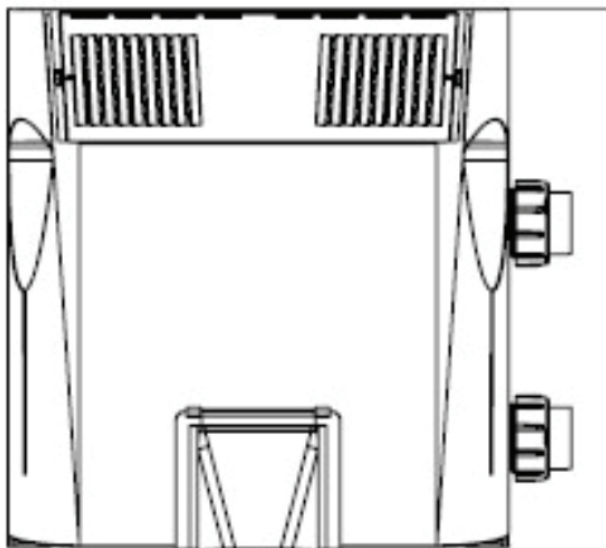

# OUTDOOR CLEARANCE

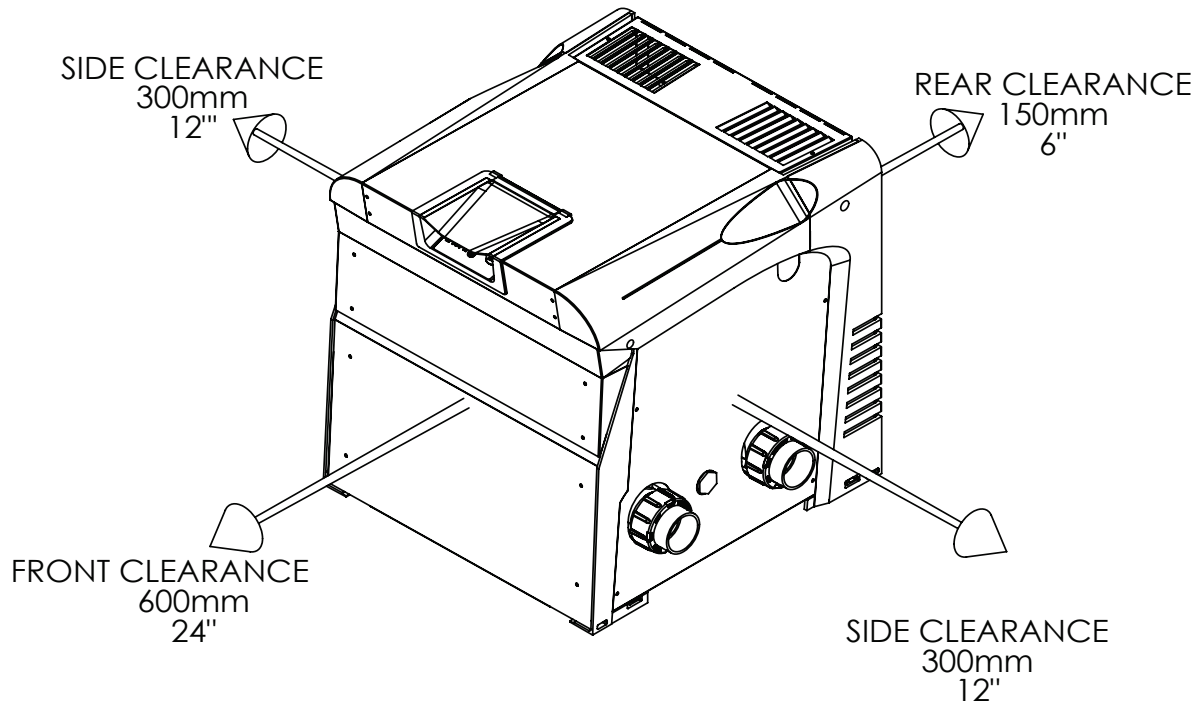

# INDOOR CLEARANCE

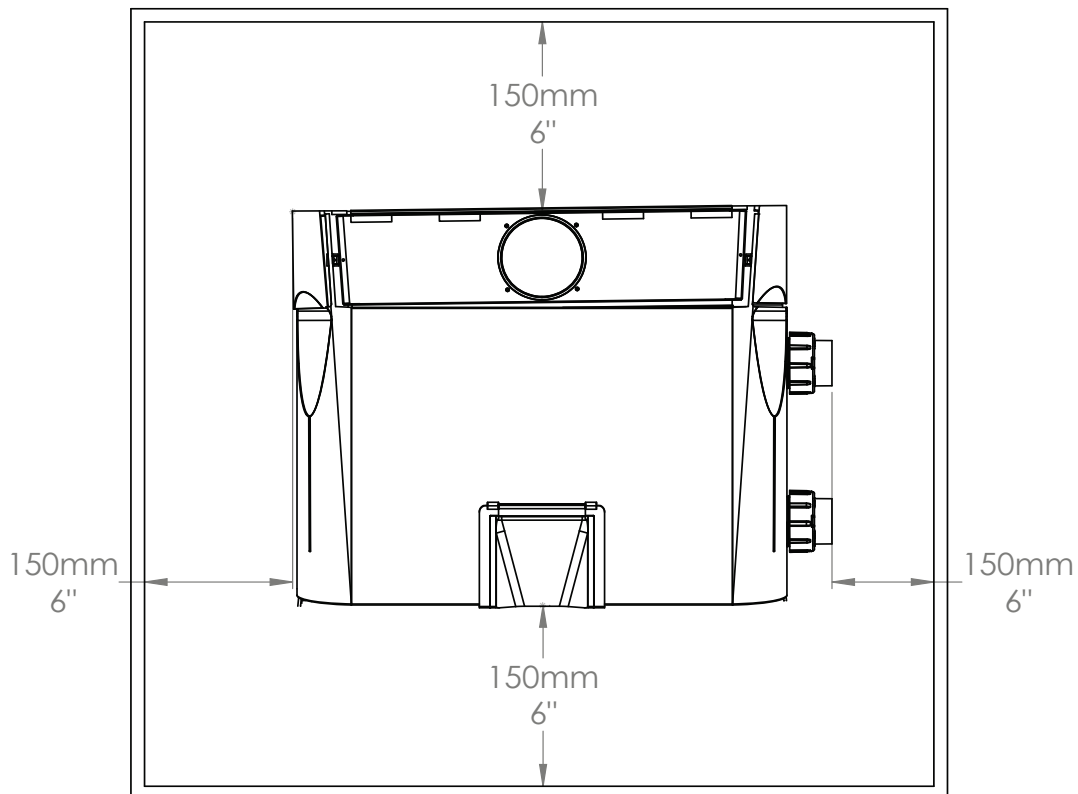

# OUTDOOR INSTALLATIONS -

Locate the heater:

- On a level Solid Surface
- 3500mm from inner pool edge unless separated by a permanent solid barrier, i.e. a wall or fence (l)
- In an open area, not under a deck or other structure
- Away from doors windows or louvers that connect in any way to occupied or inhabited areas of the building.
- Away from rainwater runoff
- Away from potential sprinkler water intrusion
- So that the top of the heater is at least 1000mm below any overhang (k)
- So that the top surface of the heater is at least 1000mm above any forced air inlet within 1000mm (k)

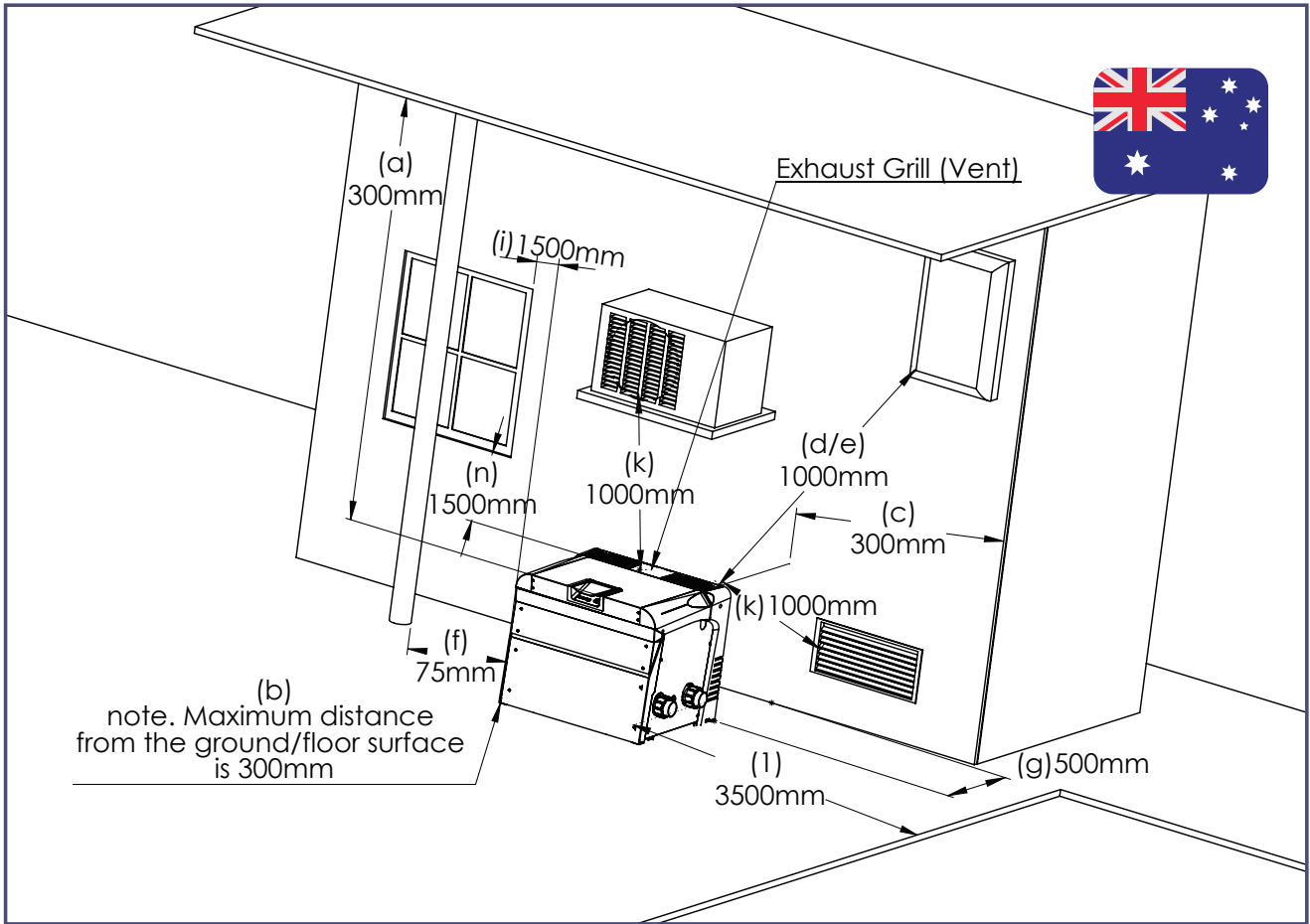

# INDOOR INSTALLATIONS - VENTING REQUIREMENTS

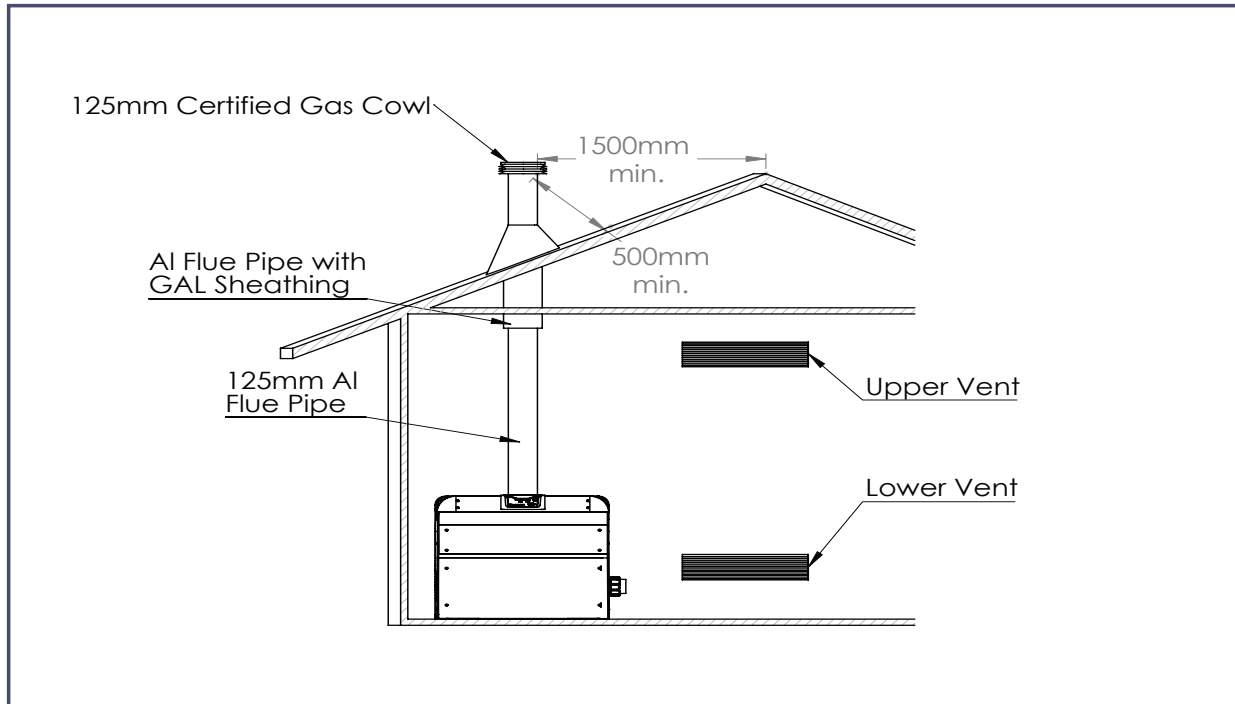

NOTE: MAXIMUM VERTICAL FLUE LENGTH IS 16m

## Natural Ventilation direct from Outside

Two permanent openings shall be provided directly to outside. The openings shall be located to ensure the distance between the top of the upper opening and the ceiling of the plant room, and the distance between the bottom of the lower opening and the floor of the plant room does not exceed 5% of the height of the plant room.

Natural Ventilation can be sourced from a non-habitable adjacent room provided the adjacent room has the same ventilation as the direct outside requirement.

The minimum free ventilation area provided by each opening is as per the following table:

Minimum Free Ventilation for each opening				
Model	Direct Outside		Via Adjacent Room	
	Square inch	Square cm	Square inch	Square cm
G9 160	74	480	149	960
G9 265	123	795	246	1,590
G9 420	186	1,200	372	2,400

# INDOOR INSTALLATIONS – VENTING REQUIREMENTS

## Maximum Flue length

The Gi Gas Heater range is certified for 125mm diameter gas flue for a maximum of 16 meters (52 ft) with three elbows. Each additional elbow reduces the maximum flue length by 3 metres. The flue may be run and terminated horizontally or vertically with a certified 125mm gas cowl. Do not use Chinaman's hat to terminate the flue or other non certified cowl.

For longer runs (above 2 or 3 metres) we recommend a twin skin flue to prevent condensation forming within the flue.

## Condensate Pump

A Condensate Pump must be fitted to the condensate drain tube located on the right side of the heater when installed indoors. The Condensate Pump incorporates a float valve and will pump the condensate up to 10 metres head. The condensate tube must be terminated outside.

Condensate Pump is available from Insrg.

# GAS CONNECTIONS

The Installation of Gas piping must be in accordance with the latest edition of ANSI Z223.1 and all local codes. The heater must be isolated from the gas supply piping system by closing the individual manual shut off valve during any pressure testing of the gas supply piping system at test pressure greater than or equal to 1/2 psi (3.5kPa).

The gas fitting line should be installed by an authorised person and comply with local regulations and Australian Standard code AS/NZ 5601. The gas line from the meter will usually be of a larger size than the gas inlet connection.

REFER TO BELOW TABLE FOR CORRECT GAS INLET PIPING LENGTH FROM THE GAS METER TO THE HEATER.

- Check the gas meter to make sure it will supply enough gas to the heater and any other appliances using the same gas supply. If unsure, contact your local gas utility to confirm.
- Install a manual gas shutoff valve outside the heater body for service and safety. Never install the shutoff valve inside the body of the heater.
- Install a sediment trap and union ahead of the gas controls and outside the heater body.
- Do not use a restrictive gas cock.

## Gas Pipe Sizing

- Pipe Sizing for Gas Line Connections
- Maximum Equivalent Pipe Length (m)
- Natural Gas Supply Pressure of 1.1kPa and pressure drop of 0.075kPa
- Propane Gas Supply Pressure of 3.0kPa and pressure drop of 0.25kPa

Model	20mm		25mm		32mm		40mm		50mm	
	NG	PG	NG	PG	NG	PG	NG	PG	NG	PG
G9160	3	30	14	120	50		140			
G9 265		12	6	50	18	160	45		220	
G9 420		5	2	25	8	80	20	200	90	

Note: Gas Pipe Sizing Tables are indicative only. All pipe sizing should be calculated by an authorised installer and according to local regulations.

MODEL		NAME	G9 160		G9 265		G9 420	
		NUMBER	21315	213157	21325	213257	21340	213407
		GAS TYPE	NATURAL	PROPANE	NATURAL	PROPANE	NATURAL	PROPANE
		GAS INLET RATE (MJ/h)	160	160	265	265	400	400
TTP (kPa) (+/-0.1)	INLET OPERATING	MIN.	1.1	2.75	1.1	2.75	1.1	2.75
		MAX.	3.5	3.5	3.5	3.5	3.5	3.5
	OUTLET OPERATING PRESSURE	0.0	0.0	0.0	0.0	0.0	0.0	0.0
		EFFICIENCY (%)	82	82	82	82	82	82
		OUTPUT (kW)	89	89	59	59	36	36

TABLE: 1

## OPERATION PERFORMANCE CHECK PROCEDURE

1. Ensure heater is turned off.
2. Remove top access panel.
3. Slacken screw in test nipple at inlet of gas valve.
4. Ensure screw in test nipple at outlet of gas valve is screwed down and closed.
5. Start pool pump.
6. Turn heater on.
7. Allow heater to start.
8. Test for gas leaks at all gas connection points up to and after valve.
9. Ensure inlet gas pressure abides by table 1.

If inlet gas pressure ok and there are no gas leaks, then continue with step 10.

If not, disconnect heater from power and close gas valve on inlet gas line. Please contact an authorised person and do not operate heater.

10. Turn off heater.
11. Remove manometer from inlet test nipple.
12. Ensure screw in test nipple is screwed down and closed.
13. Turn gas analyser on, ready to test combustion.
14. Start pool pump.
15. Turn heater on.
16. Allow heater to start.
17. Check outlet gas pressure on manometer as per table 1.
18. Place gas analyser probe in the flue outlet in direct contact with combustion gas.
19. Adjust outlet gas pressure if required.
20. Adjust CO<sub>2</sub> if required.
21. Look through site glass to ensure no yellow flames are visible.

If combustion results are ok, and a yellow flame can not be seen, then proceed to step 23.

If desired combustion results can not be achieved, disconnect heater from power and close gas valve on inlet gas line. Please contact an authorised person and do not operate heater.

22. Turn heater off.
23. Remove manometer and tighten test nipple at outlet of gas valve.
24. Fit top access panel.
25. Turn heater on again and ensure heater ignites and solid indicator appears above "OPERATING".
26. Make sure combustion results remain within specification.



# WATER CONNECTIONS

For best results the heater requires proper water flow and pressure for its operation. See below for the preferred installation. The filter pump discharges to the filter, the filter discharges to the heater, and the heater discharges directly to the pool or spa. Any chemical feeder or salt chlorinator needs to be installed downstream of the heater. A non return valve must be installed on the outlet of the heater to prevent chlorine and acid rolling back into the outlet of the heater which will void warranty. Ideally, install a chemical resistant one-way check valve between the heater and the chemical feeder to prevent back-siphoning through the heater when the pump is off. Failure to follow these recommendations can potentially cause the Heat Exchanger to corrode and void any manufacturing warranty.

## Equipment installation

A non return valve must be installed between heater and chlorinator or chemical dosing points.

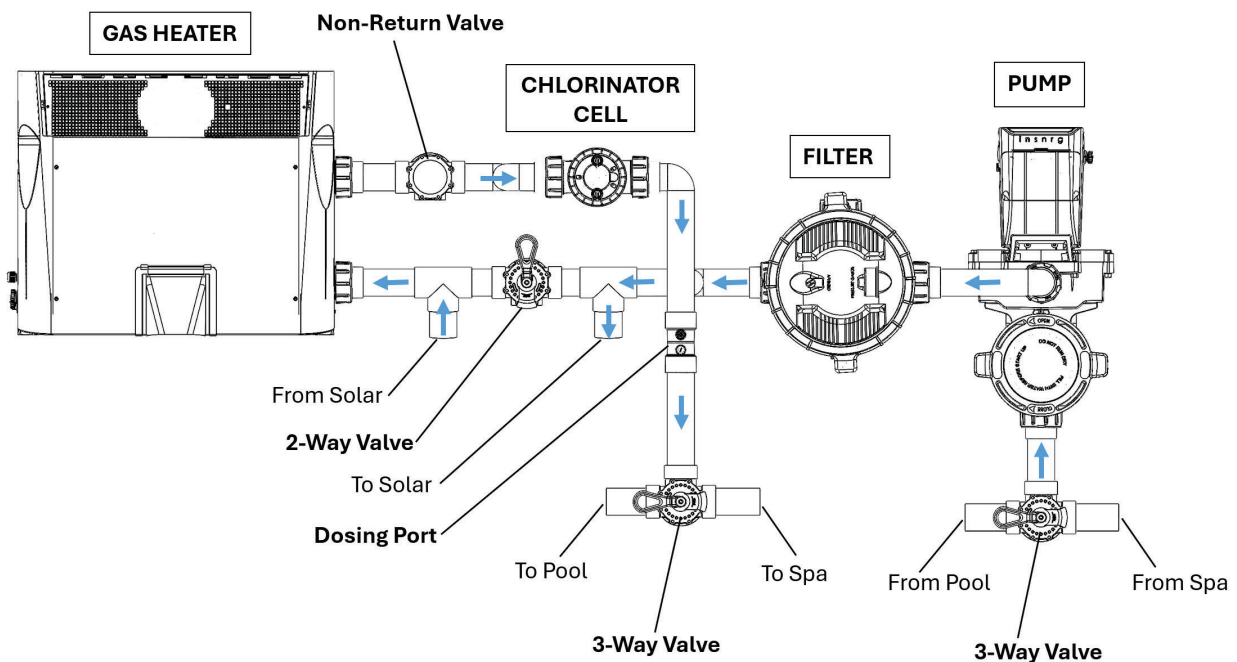

The table below outlines the minimum and maximum flow rates for the optimal performance of the heater. Installation of a manual bypass valve is required when the pump flow exceeds the maximum flow rate in the table below.

Model	Min	Max
G9 160	120 lpm	350 lpm
G9 265	150 lpm	400 lpm
G9 420	150 lpm	500 lpm

BI-PASS VALVE INSTALLATION



Warning: Incorrect Bi Pass valve setting voids warranty.

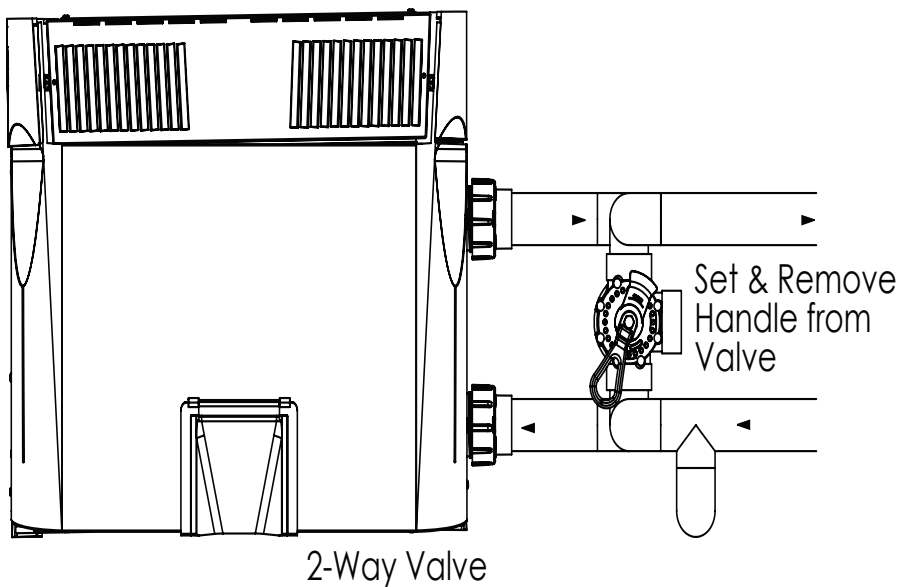

Where the flow rate exceeds the maximum 130 gpm / 500 lpm, a manual bypass should be installed and adjusted. After installing the valve, adjust to bring the flow rate to within the acceptable range. Then remove the valve handle to lock into place and avoid any tampering. Make sure to keep handle in a safe area should you need for future adjustments.

## TIPS FOR CORRECT WATER SUPPLY

- Minimise the amount of shut-off valves or other flow restrictions that could prevent flow through the heater (except for winterizing valves where needed). To switch flow between the pool and spa, use a diverter valve, ideally connected to a valve actuator for ease of use by all the family.
- Ensure that the labelled inlet and outlet are plumbed in correctly, if plumbed in backwards, the heater will cycle continuously. Connect the heater directly to 2" PVC pipe, using the unions provided. Heat sinks are not required. The low thermal mass of the heater will prevent overheating of the piping connected to the pump even if the heater shuts down unexpectedly.
- In most cases Energy Efficient and two-speed pumps will not develop enough pressure on the lowest set speeds to operate the heater. For two-speed pumps, correct by running the pump at high speed only to operate the heater. Variable Speed Pumps can be tuned to exactly the speed required for optimal performance. Ask your pool professional for more information.
- Automatic Pool Cleaners significantly affect the flow rate of water through the heater. We highly recommend not running an automatic pool cleaner whilst the heater is operating. If the cleaner is plugged (for example by leaves), there may not be adequate flow to the heater. Do not rely on the pressure switch in this case.
- It is also important to regularly maintain your selected filter and ensure that it is regularly cleaned to the requirements laid out in the appropriate operation manual. A dirty filter will increase pressure in the system and therefore reduce flow rate causing the heater not to operate at its best.

# BELOW WATER INSTALLATIONS

If the heater is installed below the water level of the Pool, the Pressure Switch must be adjusted by your professional installer.

A flow switch is required if the heater is installed more than 6' (1.8m) above the pool water level, or 6' (1.8m) below the pool water level. These levels are outside of the operating capability of the supplied pressure switch.

If the pressure switch cannot be adjusted a flow switch must be installed and wired to the pressure switch safety circuit in the heater.

## TO CHECK THE OPERATION OF THE SWITCH:

1. Pressure switch should only be checked and adjusted with clean skimmer, pump basket and filter. Ensure Pump Basket, Skimmer and Filters have been cleaned prior to adjusting Pressure Switch.
2. Connect the heater to mains power supply and turn power on. The thermostat SHOULD Not have a light above the Flow indication.
3. Turn on pump. A light should now appear above the flow indication.
4. Turn pump off. The light above the flow indicator should now be off.
5. If display does not respond in this way, adjust the pressure switch as detailed below. If display responds correctly, perform a final check with the heater operating.

## TO ADJUST PRESSURE SWITCH:

1. Pressure switch should only be checked and adjusted with clean skimmer, pump basket and filter. Flow indicator should be off.
2. Turn on pump.
3. View the display and confirm the flow light on the LCD is on.
4. With the pump running, if no flow light is on, slide the toggle on the pressure switch up to allow adjustment, then rotate the knurled wheel anti clockwise (as viewed from above) until the flow light is displayed.
5. Switch pump off.
6. Check the flow light has turned off.
7. If the flow light is on for more than one second after the pump has been turned off, the pressure switch must be adjusted.
8. With Pump turned OFF, turn knurled wheel clockwise to increase the pressure required to activate the switch.
9. Repeat steps 2 to 8 until symbol appears and disappears when pump turns on and off.
10. When the pressure switch is correctly set, slide the toggle down to lock the knurled wheel in position.
11. If pressure switch cannot be made to activate heater when pump is turned on and off, a flow switch may need to be purchased and fitted. Contact your local authorised professional.

**WARNING:** If the pressure switch cannot be adjusted correctly, **DO NOT OPERATE THE HEATER, contact your local authorised professional for assistance.**

12. Perform a final check with the heater operating.

It is imperative that the heater is installed so that it does not operate when the circulating pump stops. Recommended methods to achieve this are:

A. Correct adjustment of internal pressure switch. Ensure heater does not turn on two or three minutes after circulating pump is turned off.

B. Installation of an external flow switch may be preferred under certain installations where internal pressure switch does not turn heater off when circulator stops.

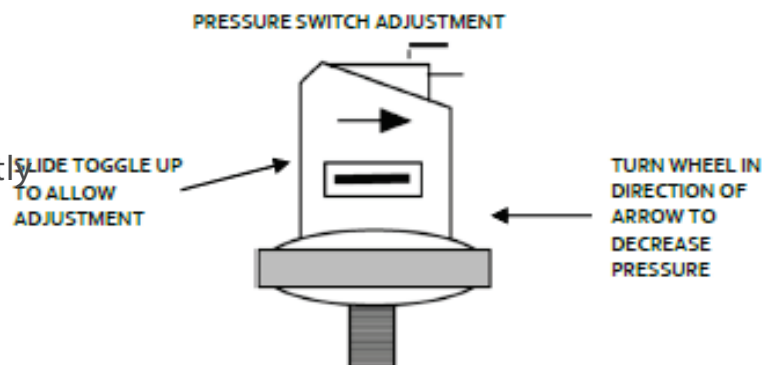

# WATER CHEMISTRY

Correct water balance not only provides you with the best water quality that all your family and friends can enjoy, it also ensures the longevity of your Gas Heater purchase. Incorrect water balance can affect components of the Gas Heater, reduce the performance and affect your warranty entitlements.

The Heat Exchanger has specially selected elements that enhance the heating capacity of your Gas Heater. These elements can corrode if exposed to high chlorine levels and pH levels outside of the recommended levels below. Corrosion of the heat exchanger voids warranty. Your local pool shop specialist or spa retailer can advise correct chemical balance. Your water should be checked and maintained regularly by a pool water professional.

As a guide the following parameters may be used:

	Pool Type					
	Concrete		Fibreglass		Vinyl Liner	
	Low	High	Low	High	Low	High
Total Alkalinity (TA)	100	200	120	170	150	200
Calcium Hardness (CH)	60	90	80	100	60	90
pH	7.6	7.8	7.4	7.6	7.6	7.8
Salinity	3500	4000	3500	4000	3500	4000
Combined Chlorine	0	0.5	0	0.5	0	0.5
Free Chlorine	1.5	3	1.5	3	1.5	3
Outdoor Pools	Cyanuric Acid (Sunscreen) 30 ppm					
Water Chemistry recommendation provided by Aqua Science Consultants.						

You should test your water chemical balance at least on a weekly basis.

Excessive sanitiser can damage your heater. Chlorine should not exceed 4 ppm and bromine should not exceed 5 ppm. Salt chlorinators, especially when used on spa pools or indoor or covered pools, can easily produce excessive chlorine levels which will damage the heater internals.

# ELECTRICAL CONNECTIONS



Heater operates on 230/240 V AC power supply only.



The heater is supplied with a 2.8m lead with 3 pin 10 amp plug.

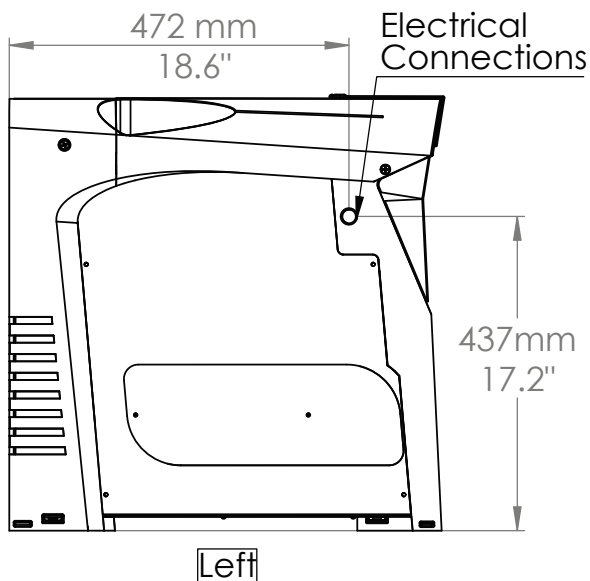

1. All wiring must be in accordance with all applicable codes.
2. The heater, when installed, must be electrically grounded and bonded in accordance with local codes
3. Electrical power circuits to the pool heater must follow local codes.
4. All wiring between the heater and devices not attached to it, or between separate devices which are installed in the field, must be "Type T" wire rated for 35 degrees Celcius rise.
5. All line voltage wiring shall be enclosed in approved flexible conduit, and shall be securely attached to the field

wiring box located inside the access door panel. The conduit or cable connector at the field wiring box should contain an insulated bushing or its equivalent to prevent abrasion of the wires as they enter the box.

6. The filter pump should run continuously when the heater is on, and for at least 5 minutes after the heater turns off. Any switches in the pump circuit (including circuit breakers) that can disconnect the pump must also disconnect the heater.

7. Do not wire single-pole switches, including protective devices, into a grounded line. The heater is sensitive to polarity. Connect the L1 of the power supply to the black wire, the L2 or neutral lead to the red wire, and the ground wire to the green wire. A time clock controlling the filter pump should have a low-voltage Fireman's Switch that switches off the heater at least 15 minutes before shutting off the pump.

Fireman's Switch remote control of heater.

1. Must be a voltage free 2 wire connection from the remote controlling switch.
2. Unclip the looped pink wire from the Wago connector on the rear of the electrical assembly.
3. Clip remote wire into Wago connector and tie off combustion chamber.



Looped Pink Wire –  
Fireman's switch connection

# Wiring Diagram Insnrng Gas Heater G9 160, G9 265, G9 420 (Australia)

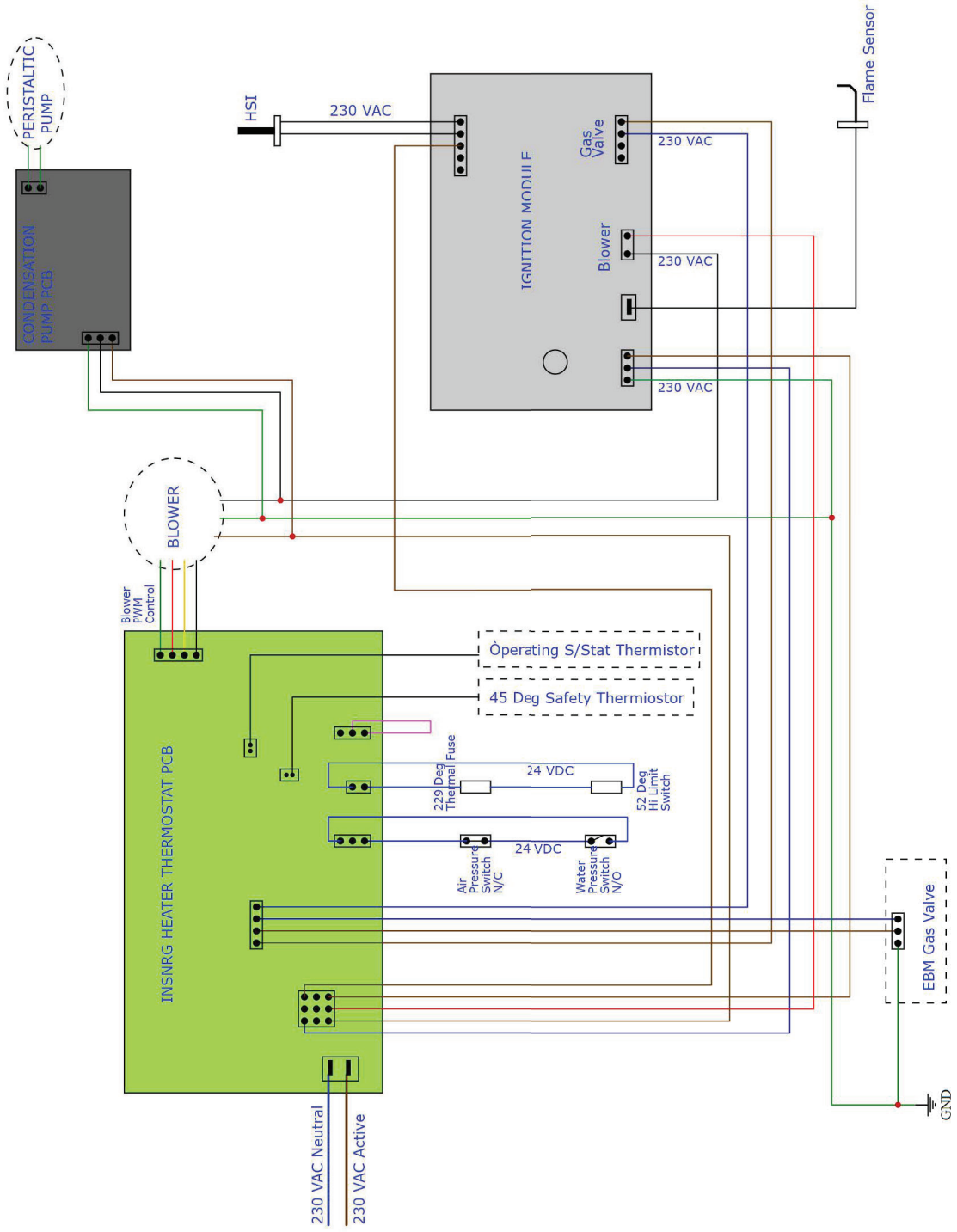

## SECTION 3

# NOW TO HAVE SOME FUN

Let's get the most out of your gas heater!

## TURNING ON/OFF

Your Insnrg Gas Heater is a high performance unit and therefore we have designed it's features to replicate the latest trends in high performance vehicles, even down to the on/off switch.

Once your unit is installed, simply press the Start/Stop button to start operation of your heater.



# IGNITION PROCESS



Your display screen will identify all you need to know to ensure the Gas Heater is operating correctly.

Use the following steps to ignite every time:

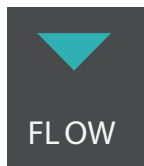

1. Turn on Operating Pump and look for a symbol to appear above the 'FLOW' mark.

If this symbol doesn't appear check for any reason why the water is not flowing through the heater. It could be a Valve closed, the Filter needs cleaning, or the Pool cleaner is blocking water flow. Clean out the system and try again.



2. Press the 'START/STOP' button

3. Wait for a symbol to appear above the 'IGNITION' mark. You should also hear the Gas Heater clicking and looking to ignite. This could take a number of times depending on Gas supplier and location of the heater.



If symbol doesn't appear check your supply of gas. Could be empty gas bottles, a valve has been turned off, your supply has been stopped for some reason. If heater has not been used for a few weeks, the gas may need to charge up the lines again. Check system and try again.

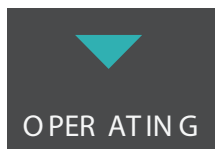

4. When the unit is operating correctly a symbol will appear above the 'OPERATING' mark and your water is being heated to your desired temperature.

# ADJUSTING THE TEMPERATURE

Now let's get your water to the perfect temperature for swimming.

## IDEAL TEMPERATURE:

Every person is different and likes the water temperature to suit themselves. However, experience has identified the following temperatures as the preferred level for swimming:

- Pool  
26-28 degrees celsius OR 78-82 degrees fahrenheit
- Spa  
36-38 degrees celsius OR 96-100 degrees fahrenheit

Your Insnrg heater has a digital display to enable you to set to exactly what temperature you desire.

## HOW TO SET TEMPERATURE:

Simply look at the screen which will tell you the current temperature of the water, then adjust the Set Point by pressing the 'UP' or 'DOWN' buttons as you require.

Once the Gas Heater reaches the Set Point, the Heater will turn off but continuously monitor the water temperature. Once it drops below the set point, it will fire up again and continue to heat your water (this is dependent on supply of water and gas).

## OTHER FEATURES: MODE BUTTON

1. To switch between pool and spa temperature press MODE to select Pool Temperature.
2. Adjust UP or DOWN to select your desired swimming temperature.
3. Now press MODE again to select Spa Temperature. Press UP or DOWN to select your desired spa temperature.
4. Once completed, there is no need to adjust the up or down temperature to change between pool or spa settings. Simply press MODE to select Pool or Spa.

# WI-FI CONNECTION

Now, let's get to the exciting stuff.

Your Insnrg Gas Heater, when connected to the optional Insnrg Vi Chlorinator and/or Relay Hub, can be controlled by the Insnrg Automation Application with the purchase of an 'Insnrg Portal' unit. The Insnrg Portal will provide a connection between the Gas Heater and your household Internet router.

This enables full control of pool and spa modes and temperatures from your smart phone, tablet or computer anywhere in the world. Just as long as you have a internet connection.

## SECTION 4

# OOPS, SOMETHING'S NOT RIGHT?

Maintenance, Trouble Shooting,  
Replacement Parts, Warranty &  
Contact Section

# MAINTENANCE

## MAINTAINING YOUR GAS HEATER

Like your motor vehicle, to keep your heater running in peak condition, we recommended a regular pro-active check at least every six months and at the beginning of every swimming season. Include the following:

1. Examine the Gas Heater, particularly the flue outlet and panel louvers for blockages. You are looking for anything that can potentially block the air-flow to and around the Gas Heater. Remove any obstructions.
2. Remind yourself of the safety rules and clearances, reread the first section of this manual. Then check the area around the heater and remove any combustibles and flammable liquids. Chlorine and Acid especially should not be stored in the vicinity of the heater. The vapours from these chemicals if drawn through a heater, can rapidly cause corrosion of the heat exchanger and other valuable components.
3. Check the heater area for any garden refuse and debris. Not only does it affect air flow and can be a potential fire hazard, the garden waste can encourage insects to nest in the unit and affect the life and reliability of your heater. A quick spray of Insect surface spray around the outside of the Gas Heater is also recommended (NOTE: ensure the Gas Heater is not operating).
4. To really get the best results and ensure your Heater is operating at full capacity, have your heater professionally inspected at least every 2 years. If you use your heater on a daily basis, have it inspected once a year. This is like an insurance for your heater, it will ensure all is running well and give you many years of enjoyment.

# WINTER OPERATION

**IF THE POOL IS NOT BEING USED FOR A MONTH OR MORE:**

Turn the heater off at the main gas isolation valve. For areas where there is no danger of freezing, water should circulate through your heater all year long even though you are not heating your pool.

**IF YOU LIVE IN AN AREA THAT HAS THE POTENTIAL FOR YOUR POOL WATER TO FREEZE, IT IS VERY IMPORTANT TO READ THE FOLLOWING:**

When water freezes, it expands. Due to the high performance of your InsnrG Gas Heater any expansion of water inside the heater can cause significant and costly damage when it expands. Therefore, it is vital to drain the water from the heater anywhere where freezing is a possibility. The easiest way to drain the heater is by loosening the inlet and/or outlet barrel union and allowing the water to drain away. If the heater is below water level, remember to close the valves before and after the heater first to isolate the heater from the pool and eliminate the possibility of draining the pool, then loosen the inlet/outlet unions and drain.



## CAUTION

If the heater has been drained for freezing conditions, remember to turn the pump on first to circulate the water and fill the heater before turning the Gas Heater on.

# TROUBLESHOOTING

SYMPTOM	POSSIBLE CAUSE	REMEDY
HEATER IN "ON MODE" BUT NOT STARTING IGNITION SEQUENCE	<ul style="list-style-type: none"> <li>No water Flow.</li> <li>Water set temperature below actual water temperature.</li> </ul>	<ul style="list-style-type: none"> <li>Ensure water circulation pump is on.</li> <li>Filter and basket are clean.</li> <li>Valves are in correct position.</li> <li>Increase temperature set point on heater.</li> </ul>
UNSTABLE COMBUSTION 1. Heater turns off and on. 2. Heater ignites slowly. 3. Flame lifts and goes out. 4. Short yellow streaked flame.	<ul style="list-style-type: none"> <li>Wrong gas type.</li> <li>Lean fuel/air mixture – low supply gas pressure.</li> <li>Lean fuel/air mixture – too much combustion air.</li> <li>Rich fuel/air mixture – high manifold pressure.</li> <li>Rich fuel/air mixture – too little combustion air.</li> </ul>	<ul style="list-style-type: none"> <li>Make sure the gas supply matches the gas type indicated on the rating plate.</li> <li>Correct gas supply inlet operating pressure to be:               <ul style="list-style-type: none"> <li>(Natural Gas) 1.1kPa min to 2.6kPa max</li> <li>(Propane Gas) 2.75kPa min to 3.5kPa.</li> </ul> </li> <li>Operating outlet pressure to be 0.0kPa Adjust valve as required.</li> <li>Gas meter too small.</li> <li>Gas line from meter to heater is undersized.</li> <li>Check blower inlet venturi for obstruction.</li> </ul>
NOT ENOUGH HEAT 1. Water is slow to heat up. 2. Heater is not maintaining set temperature within 1 degree. 3. Low temperature rise.	<ul style="list-style-type: none"> <li>Heater size is inadequate.</li> <li>Filter pump is not running long enough.</li> <li>Thermal regulator valve (TRV) is opening early or is permanently open.</li> <li>Heater plumbed backwards.</li> </ul>	<ul style="list-style-type: none"> <li>Replace with heater of higher output.</li> <li>Replace TRV.</li> <li>Heater is condensing. Flue product moisture will condense at the start-up until the heater water temperature reaches the normal operating conditions.</li> <li>Correct the plumbing.</li> </ul>
HEATER POUNDING OR KNOCKING	<ul style="list-style-type: none"> <li>Insufficient water flow through heater.</li> <li>Failed Thermal Regulator Valve (TRV).</li> <li>Rich fuel/air mixture.</li> <li>Incorrect gas type.</li> </ul>	<ul style="list-style-type: none"> <li>Look for obstruction or closed valve in system.</li> <li>Ensure heater water pressure switch is opening with filter pump off.</li> <li>Check for damaged internal bypass.</li> <li>Variable speed pump set too low.</li> <li>Dirty filter or baskets.</li> <li>Make sure the gas supply matches the gas type indicated on the rating plate.</li> </ul>
HEATER LIGHTS BUT GOES OUT IN 2 SECONDS AND REATTEMPTS IGNITION	<ul style="list-style-type: none"> <li>Incorrectly wired power supply to heater.</li> </ul>	<ul style="list-style-type: none"> <li>Make sure GPO or extension leads used to power heater are wired with Active and Neutral wires to correct pins.</li> </ul>
IGNITOR HEATS UP BUT HEATER DOES NOT LIGHT	<ul style="list-style-type: none"> <li>Gas cock is not open.</li> <li>Air in gas line.</li> <li>No Power to gas valve.</li> <li>Low gas pressure / volume.</li> <li>Gas Valve.</li> </ul>	<ul style="list-style-type: none"> <li>Open gas cock.</li> <li>Cycle ignition sequence until air is out of the gas line.</li> <li>Check controls for proper operation.</li> <li>Check supply pressure/volume and verify proper gas supply pipe size.</li> <li>Replace gas valve.</li> </ul> <p>NOTE: Gas valve failures are extremely rare. Please confirm this as the root cause before replacing.</p>



# REPLACEMENT PARTS

## GAS HEATER

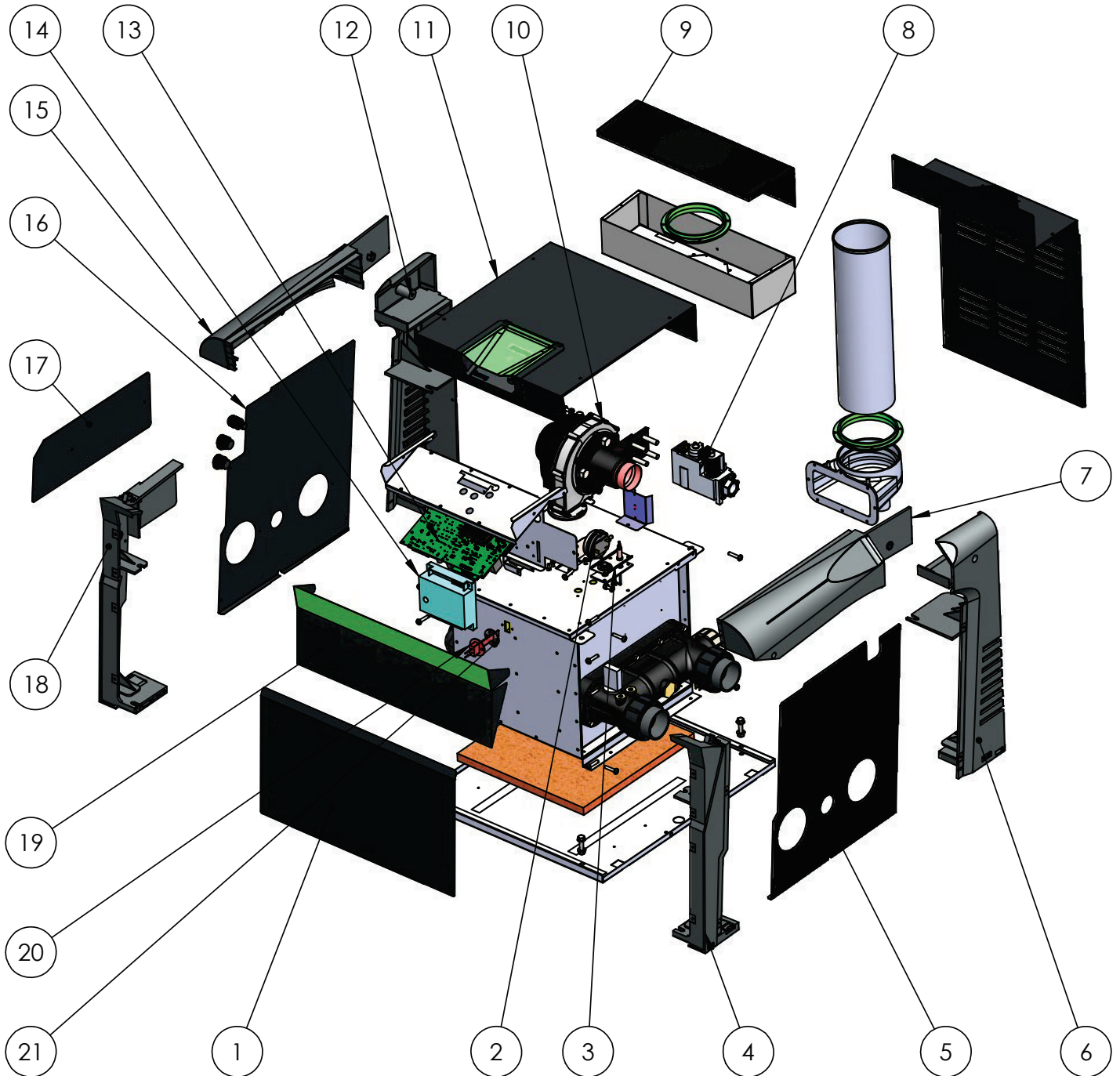

ITEM	PART NUMBER	DESCRIPTION	QTY.
1	21C15101015	Front Lower Cover (160 Heater)	1
1	21C25101019	Front Lower Cover (265 Heater)	1
1	21C40101023	Front Lower Cover (420 Heater)	1
2	211015	Air Pressure Switch	1
3	21101510001	Flame Sensor	1
3	21C0160007	Flame Sensor Gasket	1
4	21101401003	Front Right Pillar	1
5	21C01101013	Right Cover Panel	1
6	21101401005	Rear Right Pillar	1
7	21101401001	Lid Rail Right Side	1
8	21102151	Gas Valve	1
9	21115100160	Indoor Flue Cover (160 Heater)	1
9	21125100265	Indoor Flue Cover (265 Heater)	1
9	21140100420	Indoor Flue Cover (420 Heater)	1
9	21C15101005	Outdoor Flue Cover (160 Heater)	1
9	21C25101110	Outdoor Flue Cover (265 Heater)	1
9	21C4010112	Outdoor Flue Cover (420 Heater)	1
10	21201	Blower Assembly Combustion	1
	21C00310060	Combustion Blower	1
	211011513002	O ring Venturi to Blower	1
	21C01602004	Blower Gasket	1
	211011513001	Venturi PreMix Combustion	1
11	21214001	Top Assembly (160 Heater)	1
11	21225002	Top Assembly (265 Heater)	1
11	21240003	Top Assembly (420 Heater)	1
12	21101401006	Rear Left Pillar	1
13	21101509	Thermostat PCB	1
14	21C01506002	Heater Control Module	1
15	21101401002	Lid Rail Left Side	1
16	21C01101014	Left Cover Panel	1
17	21C01101027	Blanking Plate LH or RH	1
18	21101401004	Front Left Pillar	1
19	21C15101016	Front Upper Cover (160 Heater)	1
19	21C25101020	Front Upper Cover (265 Heater)	1
19	21C40101024	Front Upper Cover (420 Heater)	1
20	21C01501001	220-240V Hot Surface Ignitor	1
21	21C01600006	Hot Surface Ignitor Gasket	1
22	21101515001	Wiring Loom - High Voltage	1
23	21101515002	Wiring Loom - Low Voltage	1
24	21101510	Thermistor Leads	2
25	21101900002	10 Amp Power Cord	1
26	21C01600020	Flame Sensor Wire Harness	1
27	21101501001	Valve Connection LH Lead	1

# COMBUSTION CHAMBER

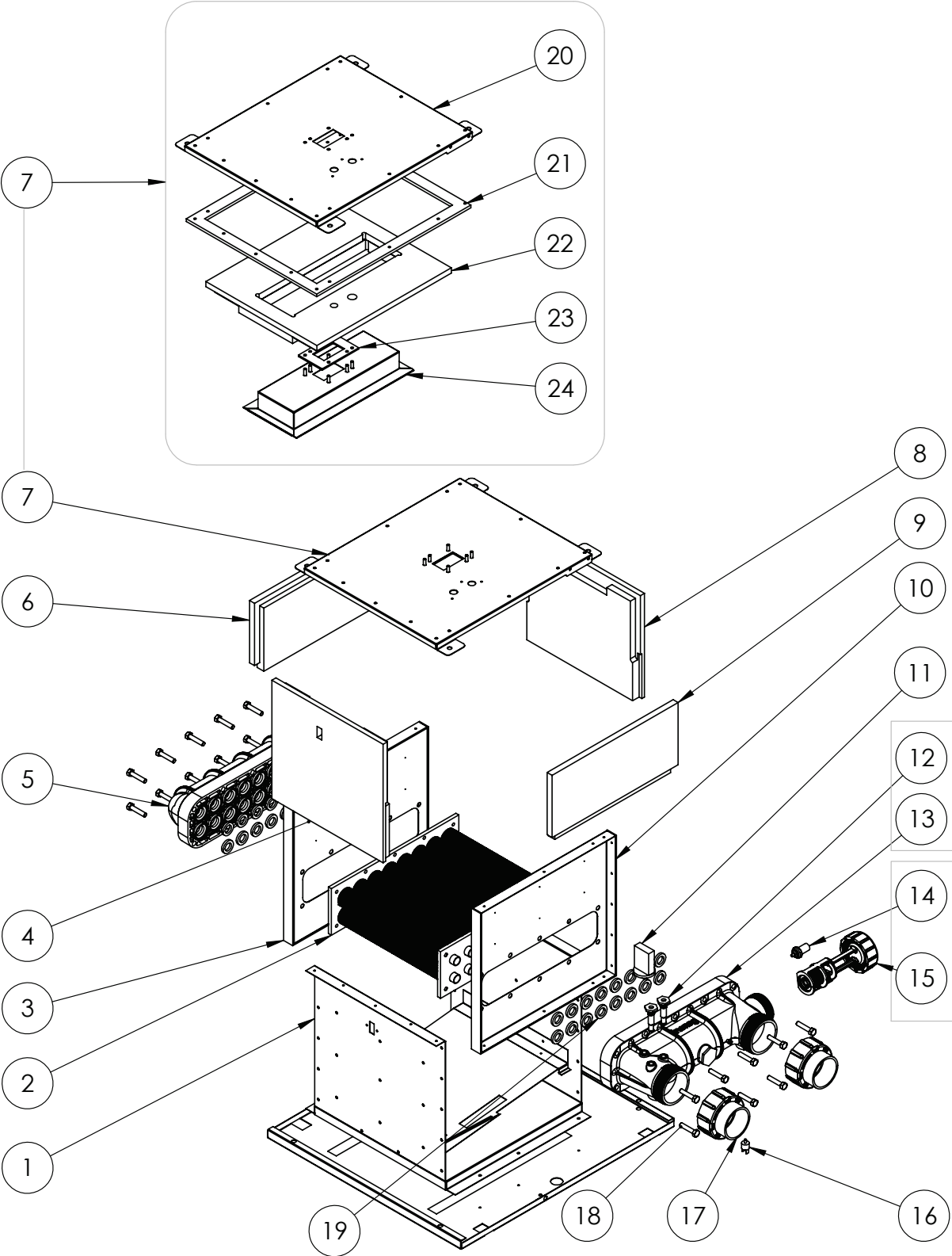

ITEM	PART NUMBER	DESCRIPTION	QTY.
1	21C15106005	Combustion Panel 160	1
1	21C25106003	Combustion Panel 265	1
1	21C40106001	Combustion Panel 420	1
2	21215020	Heat Exchanger Assembly 160	1
2	21225021	Heat Exchanger Assembly 265	1
2	21240022	Heat Exchanger Assembly 420	1
3	21C01106007	Combustion Side Panel Return Side	1
4	21C15601009	Refractory Front 160	1
4	21C25601006	Refractory Front 265	1
4	21C40601002	Refractory Front 420	1
5	211500	Return Header Assembly	1
6	21C01601003	Refractory Common Left Side all models, Right 265, 420	1
7	21215010	Combustion Chamber Top Assembly 160	1
7	21225010	Combustion Chamber Top Assembly 265	1
7	21240010	Combustion Chamber Top Assembly 420	1
8	21C15601008	Refractory Rear 160	1
8	21C25601005	Refractory Rear 265	1
8	21C40601001	Refractory Rear 420	1
9	21C01601004	Refractory Right Side 160	1
10	21C01106002	Combustion Side Panel Inlet Side	1
11	8001403	Water Pressure Switch	1
12	21C01201002	Temperature Thermistor Well	2
13	211700	Inlet Header Assembly	1
14	21C01503001	Bypass Thermostat Element	1
15	21201010	Thermostatic Bypass Valve Assembly	1
16	21C01513001	Hi Limit 52 DEG N/C	1
17	15201001	Union Assembly 50mm / 2"	2
18	10101003	5/6-18UNC x 1.5" HEX SEMS SS	20
19	21C01602007	Tube Seal Gasket Silicone	32
20	21C15106006	Combustion Chamber Top Panel 160	1
20	21C25106004	Combustion Chamber Top Panel 265	1
20	21C40106002	Combustion Chamber Top Panel 420	1
21	21C15600004	Combustion Top Insulation 160	1
21	21C25600003	Combustion Top Insulation 265	1
21	21C40600002	Combustion Top Insulation 420	1
22	21C15601010	Refractory Top 160	1
22	21C25601007	Refractory Top 265	1
22	21C40601004	Refractory Top 420	1
23	21C01600005	Burner Gasket Common	1
24	21215001	Burner Assembly 160	1
24	21225001	Burner Assembly 265	1
24	21240001	Burner Assembly 420	1

# WARRANTY

Insnrng products are designed and manufactured to the highest possible standards of performance.

## Australian Consumer Law

Our goods come with guarantees that cannot be excluded under the Australian Consumer Law. You are entitled to a replacement or refund for a major failure and for compensation for any other reasonably foreseeable loss or damage. You are also entitled to have the goods repaired or replaced if the goods fail to be of acceptable quality and the failure does not amount to a major failure.

## Warranty Period and Conditions

Insnrng Techne Pty. Ltd. (hereinafter “the Company”) is pleased to warrant to the original retail purchaser that this product shall be free of manufacturing and material defects for the period defined in the table below.

1. The product is purchased new from an authorised Insnrg dealership in Australia, New Zealand.
2. This warranty is not assignable and applies to the original retail purchaser only and the original receipt, invoice or any other proof of purchase must be retained and produced if requested by the Company.
3. Nothing in this warranty shall apply to any defects caused by misuse or abuse, neglect, accident, extremes of climate, dampness, humidity, reasonable fair wear and tear and/ or any causes other than defects in manufacturing and materials. Proper care and maintenance information is detailed in the Owner’s Manual for this product which you must follow.
4. Where a defect is physically visible or otherwise affects the exterior surfaces of the product, you must notify the Company of such defect within fourteen (14) days from the date of your purchase.
5. If the product is bought as a demonstration, refurbished, ex-rental, discontinued or otherwise previously unboxed unit, the warranty applicable shall be limited to twelve (12) months only.

## Warranty Claim Procedure

PARTS	WARRANTY PERIOD	
	RESIDENTIAL INSTALL	COMMERCIAL INSTALL
Cabinet	3 Years	2 Years
Combustion Chamber inc. Heat Exchanger, headers, refractory insulation and burner	2 Years	1 Year
Components such as gas valve, blower, thermostat,	1 Year	1 Year
Flame Sensor	2 Years	1 Year
Hot Surface Ignitor	5,000 attempts or 2 years (Whichever comes first)	5,000 attempts or 2 years (Whichever comes first)
Condensation pump	1 Year	1 Year

To exercise your rights under this warranty, you must:

Within fourteen (14) days of you becoming aware of any defect, report the following details to the dealership from which the product was purchased:

- Your name, address and contact information;
- Model, and serial number of the product; and
- A detailed description of the defect.

On receipt of the above information, the Company will allocate to your dealership an Insrg Authorisation Number (IAN).

Depending on the model type, how it is installed, and the defect reported, your nominated dealership will advise on how the warranty service will be performed. This could include, but not limited to, return of product to the dealership, return of product to the company, or a visit by qualified service technician to your poolside.

If advised to return the product, place the defective product in secure packaging, clearly label it with the IAN number allocated and send it to the address of the authorised service agent which will be advised by your dealership.

The Company will not be liable for any transportation costs, or in the event that a poolside call is arranged with an authorised service technician, costs of technician's travel time if the defect is found not to be covered by the consumer guarantees.

In the case of returned product, the authorised service technician or dealership will contact the purchaser when the product has been repaired and is ready for collection.

The Company will repair or replace at its absolute discretion your product at no cost for parts or labour in accordance with the terms stated in this warranty provided that the reported defect is able to be located by the technical staff assigned to the product. If the technical staff is unable to locate the defect, you may be liable to pay for the cost of the technician's travel time and labour. Any work undertaken will be performed during normal business hours.

The equipment must be installed in a location that allows for regular maintenance, service and repair by authorised technicians. Work will not be undertaken if a technician can be put at risk due to restricted access or working from heights.

The company manufactures and supplies products to installers and distributors. Any advice or recommendations given by third parties is not the responsibility of the company. This includes but is not limited to heater model selection, gas line sizing, gas meter capacity, water supply or electrical supply to unit.

The logo for insnrg features the word 'insnrg' in a lowercase, rounded sans-serif font. The 'i' is teal, 'n' is orange, 's' is teal, 'n' is teal, 'r' is teal, and 'g' is teal. To the right of the text is a large, stylized graphic element consisting of a teal vertical bar on the left and an orange vertical bar on the right, both with rounded ends.

We know that you will get many years of enjoyment from this product.

We pride ourselves on developing products that are specifically created for your lifestyle. We are continuously developing new products and ideas to make pool ownership easier and more enjoyable.

Should you wish to keep updated with our progress and hear first hand about our new products and developments, please feel free to stay in touch by using any or all of the below methods:

#### MAIL

57-59 Nantilla Rd,  
Clayton, VIC, 3168

#### LANDLINE

1800 INSNRG (1800 467674)

#### WEBSITE

[www.insnrg.com](http://www.insnrg.com)





insnrg

POOL AND SPA EQUIPMENT