

INSTALLATION & OPERATING MANUAL

Hi Heat Pump Top Discharge

A COMPLETE GUIDE TO YOUR HEAT PUMP



IMPORTANT NOTE:

Thank you very much for purchasing our product. Before using your unit, please read this manual carefully and keep it for future reference.

insnrg

CONTENT

| | |
|---|-----------|
| INSTALLATION & OPERATING MANUAL..... | 1 |
| 1. FOREWORD..... | 1 |
| 1.1. Read the Manual Before Operation..... | 1 |
| 1.2. The Symbol Description of the Device..... | 7 |
| 1.3. Statement | 7 |
| 1.4. Safety Factors..... | 7 |
| 2. OVER VIEW OF THE UNIT..... | 9 |
| 2.1. Accessories Supplied With the Unit..... | 9 |
| 2.2. Dimensions of the Unit | 9 |
| 2.3. Main Parts of the Unit | 10 |
| 2.4 Parameter of the Unit..... | 11 |
| 3. INSTALLATION AND CONNECTION..... | 12 |
| 3.1 Notice Before Installation | 12 |
| 3.2 Installation Instruction..... | 12 |
| 3.2.1 Pre-installation..... | 12 |
| 3.2.2 Installation The Heat Pump | 13 |
| 3.2.3 Location and Space | 14 |
| 3.2.4 Installation Layout | 15 |
| 3.2.5 Electrical Installation..... | 16 |
| 3.1. Trial After Installation | 18 |
| 3.4.1 Inspection Before Trial Running..... | 18 |
| 3.4.2 Trial Running | 18 |
| 3. REMOTE CONTROLLER OPERATION GUIDANCE..... | 19 |
| 4.1. Control Panel Diagram | 19 |
| 4.2 Operation instruction | 20 |
| (1) In the timer reservation interface, short press the  to enter the Timer 1 ON, Timer 1 OFF, System Status | 22 |
| 4.3 Operation Parameters | 25 |
| 4.4 Error Code..... | 26 |
| 4.2. Wi-Fi Settings (Not recommended if using Insrng inTouch App – only use if no other System App is connected) | 29 |
| 4.5.1 Software Installation | 29 |
| 4.5.2 Software Startup | 30 |
| 4.5.3 Software Registration and Configuration | 30 |
| 4.5.4 Software Function Operation | 37 |
| 4.5.5 Device Removal | 42 |
| 4. MAINTENANCE AND WINTERZING | 43 |
| 5.1. Maintenance..... | 43 |
| 5.2. Winterizing..... | 43 |
| WARRANTY..... | 44 |

1. FOREWORD

1.1. Read the Manual Before Operation

WARNING

Do not use means to accelerate the defrosting process or to clean, other than those recommended by the manufacturer. The appliance shall be stored in a room without continuously operating ignition sources (for example: open flames, an operating gas appliance or an operating electric heater).

Do not pierce or burn. Be aware that refrigerants may not contain an odor.

SERVICE ACCESS

Despite any clearances specified for the proper operation of the unit, safe service access must be provided for future service work. Insrng Service Technicians are trained not to endanger themselves by climbing or performing unsafe maneuvers while attempting to service the Heat Pump.

Initial safety checks shall include:

- ① That capacitors are discharged: this shall be done in a safe manner to avoid possibility of sparking;
- ② That no live electrical components and wiring are exposed while charging, recovering or purging the system;
- ③ That there is continuity of earth bonding.

Checks to the area

Prior to beginning work on systems containing flammable refrigerants, safety checks are necessary to ensure that the risk of ignition is minimized. For repair to the refrigerating system, the following precautions shall be completed prior to conducting work on the system.

Work procedure

Work shall be undertaken under a controlled procedure so as to minimize the risk of a flammable gas or vapour being present while the work is being performed.

General work area

All maintenance staff and others working in the local area shall be instructed on the nature of work being carried out. Work in confined spaces shall be avoided.

Checking for presence of refrigerant

The area shall be checked with an appropriate refrigerant detector prior to and during work, to ensure the technician is aware of potentially flammable atmospheres. Ensure that the leak detection equipment being used is suitable for use with flammable refrigerants, i.e. non-sparking, adequately sealed or intrinsically safe.

Presence of fire extinguisher

If any hot work is to be conducted on the refrigerating equipment or any associated parts,

appropriate fire extinguishing equipment shall be available to hand. Have a dry powder or CO2 fire extinguisher adjacent to the charging area.

No ignition sources

No person carrying out work in relation to a refrigeration system which involves exposing any pipe work that contains or has contained flammable refrigerant shall use any sources of ignition in such a manner that it may lead to the risk of fire or explosion. All possible ignition sources, including cigarette smoking, should be kept sufficiently far away from the site of installation, repairing, removing and disposal, during which flammable refrigerant can possibly be released to the surrounding space. Prior to work taking place, the area around the equipment is to be surveyed to make sure that there are no flammable hazards or ignition risks. "No Smoking" signs shall be displayed.

Ventilated area

Ensure that the area is in the open or that it is adequately ventilated before breaking into the system or conducting any hot work. A degree of ventilation shall continue during the period that the work is carried out. The ventilation should safely disperse any released refrigerant and preferably expel it externally into the atmosphere.

Checks to the refrigeration equipment

Where electrical components are being changed, they shall be fit for the purpose and to the correct specification. At all times the manufacturer's maintenance and service guidelines shall be followed. If in doubt consult the manufacturer's technical department for assistance.

The following checks shall be applied to installations using flammable refrigerants:

- ① The charge size is in accordance with the room size within which the refrigerant containing parts are installed;
- ② The ventilation machinery and outlets are operating adequately and are not obstructed;
- ③ If an indirect refrigerating circuit is being used, the secondary circuit shall be checked for the presence of refrigerant;
- ④ Marking to the equipment continues to be visible and legible. Markings and signs that are illegible shall be corrected;
- ⑤ Refrigeration pipe or components are installed in a position where they are unlikely to be exposed to any substance which may corrode refrigerant containing components, unless the components are constructed of materials which are inherently resistant to being corroded or are suitably protected against being so corroded.

Repairs to sealed components

DD.5.1 During repairs to sealed components, all electrical supplies shall be disconnected from the equipment being worked upon prior to any removal of sealed covers, etc. If it is absolutely necessary to have an electrical supply to equipment during servicing, then a permanently operating form of leak detection shall be located at the most critical point to warn of a potentially hazardous situation.

DD.5.2 Particular attention shall be paid to the following to ensure that by working on electrical

components, the casing is not altered in such a way that the level of protection is affected. This shall include damage to cables, excessive number of connections, terminals not made to original specification, damage to seals, incorrect fitting of glands, etc.

Ensure that the apparatus is mounted securely.

Ensure that seals or sealing materials have not degraded to the point that they no longer serve the purpose of preventing the ingress of flammable atmospheres. Replacement parts shall be in accordance with the manufacturer's specifications.

Repair to intrinsically safe components

Do not apply any permanent inductive or capacitance loads to the circuit without ensuring that this will not exceed the permissible voltage and current permitted for the equipment in use. Intrinsically safe components are the only types that can be worked on while live in the presence of a flammable atmosphere. The test apparatus shall be at the correct rating.

Replace components only with parts specified by the manufacturer. Other parts may result in the ignition of refrigerant in the atmosphere from a leak.

NOTE The use of silicon sealant can inhibit the effectiveness of some types of leak detection equipment.

Intrinsically safe components do not have to be isolated prior to working on them.

Cabling

Check that cabling will not be subject to wear, corrosion, excessive pressure, vibration, sharp edges or any other adverse environmental effects. The check shall also take into account the effects of aging or continual vibration from sources such as compressors or fans.

Detection of flammable refrigerants

Under no circumstances shall potential sources of ignition be used in the searching for or detection of refrigerant leaks. A halide torch (or any other detector using a naked flame) shall not be used.

Leak detection methods

The following leak detection methods are deemed acceptable for systems containing flammable refrigerants.

Electronic leak detectors shall be used to detect flammable refrigerants, but the sensitivity may not be adequate, or may need re-calibration. (Detection equipment shall be calibrated in a refrigerant-free area.) Ensure that the detector is not a potential source of ignition and is suitable for the refrigerant used. Leak detection equipment shall be set at a percentage of the LFL of the refrigerant and shall be calibrated to the refrigerant employed and the appropriate percentage of gas (25 % maximum) is confirmed.

Leak detection fluids are suitable for use with most refrigerants but the use of detergents containing chlorine shall be avoided as the chlorine may react with the refrigerant and corrode the copper pipe-work.

If a leak is suspected, all naked flames shall be removed/extinguished.

If a leakage of refrigerant is found which requires brazing, all of the refrigerant shall be recovered from the system, or isolated (by means of shut off valves) in a part of the system remote from the

leak. Oxygen free nitrogen (OFN) shall then be purged through the system both before and during the brazing process.

Removal and evacuation

When breaking into the refrigerant circuit to make repairs – or for any other purpose – conventional procedures shall be used. However, it is important that best practice is followed since flammability is a consideration. The following procedure shall be adhered to:

- ① Remove refrigerant;
- ② Purge the circuit with inert gas;
- ③ Evacuate;
- ④ Purge again with inert gas;
- ⑤ Open the circuit by cutting or brazing.

The refrigerant charge shall be recovered into the correct recovery cylinders. The system shall be “flushed” with OFN to render the unit safe. This process may need to be repeated several times. Compressed air or oxygen shall not be used for this task.

Flushing shall be achieved by breaking the vacuum in the system with OFN and continuing to fill until the working pressure is achieved, then venting to atmosphere, and finally pulling down to a vacuum. This process shall be repeated until no refrigerant is within the system. When the final OFN charge is used, the system shall be vented down to atmospheric pressure to enable work to take place. This operation is absolutely vital if brazing operations on the pipework are to take place.

Ensure that the outlet for the vacuum pump is not close to any ignition sources and there is ventilation available.

Charging procedures

In addition to conventional charging procedures, the following requirements shall be followed:

- ① Ensure that contamination of different refrigerants does not occur when using charging equipment. Hoses or lines shall be as short as possible to minimize the amount of refrigerant contained in them. Cylinders shall be kept upright.
- ② Ensure that the refrigeration system is earthed prior to charging the system with refrigerant.
- ③ Label the system when charging is complete (if not already).
- ④ Extreme care shall be taken not to overfill the refrigeration system. Prior to recharging the system it shall be pressure tested with OFN. The system shall be leak tested on completion of charging but prior to commissioning. A follow up leak test shall be carried out prior to leaving the site.

Decommissioning

Before carrying out this procedure, it is essential that the technician is completely familiar with the equipment and all its detail. It is recommended good practice that all refrigerants are recovered safely. Prior to the task being carried out, an oil and refrigerant sample shall be taken in case analysis is required prior to re-use of reclaimed refrigerant. It is essential that electrical power is available before the task is commenced.

- ① Become familiar with the equipment and its operation.
- ② Isolate system electrically.

- ③ Before attempting the procedure ensure that:
 - Mechanical handling equipment is available, if required, for handling refrigerant cylinders;
 - All personal protective equipment is available and being used correctly;
 - The recovery process is supervised at all times by a competent person;
 - Recovery equipment and cylinders conform to the appropriate standards.
 - ④ Pump down refrigerant system, if possible.
 - ⑤ If a vacuum is not possible, make a manifold so that refrigerant can be removed from various parts of the system.
 - ⑥ Make sure that cylinder is situated on the scales before recovery takes place.
 - ⑦ Start the recovery machine and operate in accordance with manufacturer's instructions.
 - ⑧ Do not overfill cylinders. (No more than 80 % volume liquid charge).
 - ⑨ Do not exceed the maximum working pressure of the cylinder, even temporarily.
 - ⑩ When the cylinders have been filled correctly and the process completed, make sure that the cylinders and the equipment are removed from site promptly and all isolation valves on the equipment are closed off.
- 11 Recovered refrigerant shall not be charged into another refrigeration system unless it has been cleaned and checked.

Labeling

Equipment shall be labeled stating that it has been decommissioned and emptied of refrigerant. The label shall be dated and signed. Ensure that there are labels on the equipment stating the equipment contains flammable refrigerant.

Recovery

When removing refrigerant from a system, either for servicing or decommissioning, it is recommended good practice that all refrigerants are removed safely. When transferring refrigerant into cylinders, ensure that only appropriate refrigerant recovery cylinders are employed. Ensure that the correct number of cylinders for holding the total system charge are available. All cylinders to be used are designated for the recovered refrigerant and labeled for that refrigerant (i.e. special cylinders for the recovery of refrigerant). Cylinders shall be complete with pressure relief valve and associated shut-off valves in good working order. Empty recovery cylinders are evacuated and, if possible, cooled before recovery occurs.

The recovery equipment shall be in good working order with a set of instructions concerning the equipment that is at hand and shall be suitable for the recovery of flammable refrigerants.

In addition, a set of calibrated weighing scales shall be available and in good working order.

Hoses shall be complete with leak-free disconnect couplings and in good condition. Before using the recovery machine, check that it is in satisfactory working order, has been properly maintained and that any associated electrical components are sealed to prevent ignition in the event of a refrigerant release. Consult manufacturer if in doubt.





The recovered refrigerant shall be returned to the refrigerant supplier in the correct recovery cylinder, and the relevant Waste Transfer Note arranged. Do not mix refrigerants in recovery units and especially not in cylinders.

If compressors or compressor oils are to be removed, ensure that they have been evacuated to an acceptable level to make certain that flammable refrigerant does not remain within the

lubricant. The evacuation process shall be carried out prior to returning the compressor to the suppliers. Only electric heating to the compressor body shall be employed to accelerate this process. When oil is drained from a system, it shall be carried out safely.

1.2. The Symbol Description of the Device

The precautions listed here are divided into the following types. They are quite important, so be sure to follow them carefully. Meanings of DANGER, WARNING, CAUTION and NOTE symbols.

| Symbols | Meaning | Description |
|---|----------------|--|
|  | WARNING | The symbol shows that this appliance uses a flammable refrigerant. If the refrigerant is leaked and exposed to an external ignition source, there is a risk of fire. |
|  | WARNING | The symbol shows that this appliance uses a low burning velocity material. Please keep away from fire source. |
|  | CAUTION | This symbol shows that the operation manual should be read carefully. |
|  | CAUTION | This symbol shows that a service personnel should be handling this equipment with reference to the installation manual. |
|  | CAUTION | This symbol shows that information is available such as the operating manual or installation manual. |

1.3. Statement

To keep users and property safe, please follow the instructions below :

- ① Incorrect operation may result in injury or damage;
- ② Please install the unit in compliance with local laws, regulations and standards;
- ③ Confirm power voltage and frequency;
- ④ This unit must be earthed correctly;
- ⑤ An isolation switch must be installed with this unit.

1.4. Safety Factors

The following safety factors need to be considered:

- ① Please read the following warnings before installation;
- ② Be sure to check the details that need attention, including safety factors;
- ③ After reading the installation instructions, be sure to save them for future reference.

 **Warning**

Make sure that the unit is installed safely and reliably.

- If the unit is not secure or not installed, it may cause damage. The minimum support weight required for installation is 21g/mm²

- The unit must not be installed in a closed area or limited space.

- ① Use a specific wire and fasten it to terminal block so that the connection will prevent pressure from being applied to parts.

- ② Wrong wiring will cause fire.

Please connect power wire accurately according to wiring diagram on the manual to avoid burnout of the unit or fire.

- ③ Be sure to use correct material during installing.

Incorrect parts or wrong materials may result in fire, electric shock, or falling of the unit.

- ④ Install on the ground safely, please read installation instructions.

Improper installation may result in fire, electric shock, falling of the unit, or water leaking.

- ⑤ Use professional tools for doing electrical work.

If power supply capacity is insufficient or circuit is not completed, it may cause fire or electric shock.

- ⑥ The unit must have grounding device.

If power supply does not have grounding device, be sure not to connect the unit.

- ⑦ The unit should be only removed and repaired by professional technician.

Improper movement or maintenance of the unit may cause water leakage, electric shock, or fire.

Please find a professional technician to do.

- ⑧ Don't unplug or plug power during operation. This may cause fire or electric shock.

- ⑨ Don't touch or operate the unit when your hands are wet. It may cause fire or electric shock.

- ⑩ Don't place heaters or other electrical appliances near the power wire. It may cause fire or electric shock.

- 11 The water must not be poured directly on the unit. Do not let water to permeate into the electrical components.

 **Warning**

- ① Do not install the unit in a location where there may be flammable gas.

- ② If flammable gas is around unit, it may cause a fire or explosion. Follow drainage system and pipeline work instructions.

- ③ Do not clean unit with power on. Turn off power before cleaning to avoid injury from rotating fan or electric shock.

- ④ Stop unit operation upon problem/fault code. Turn off power to prevent electric shock/fire.

- ⑤ Be careful when unit is unpacked/uninstalled. Watch for sharp edges/fins of heat exchanger.

- ⑥ After installation/repair, confirm no refrigerant leakage. Insufficient refrigerant impairs unit operation.

- ⑦ Install external unit on a level surface and the base must not subside to avoid abnormal vibration/noise.

- ⑧ Do not insert fingers into fan/evaporator. High-speed fan causes serious injury.

- ⑨ This appliance is not intended for use by persons (including children) with reduced physical, sensory or mental capabilities, or lack of experience and knowledge, unless they have been given supervision or instruction concerning use of the appliance by a person responsible for their safety.

2. OVER VIEW OF THE UNIT

2.1. Accessories Supplied With the Unit

After unpacking, please check if you have all the following components.

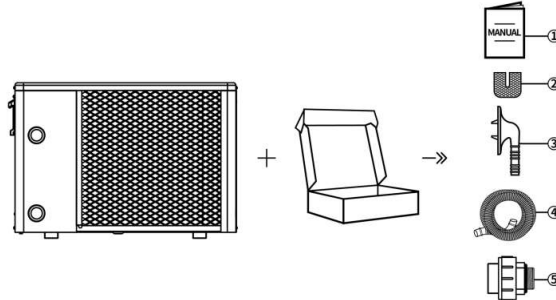

| NO. | Components | Quantity | NO. | Components | Quantity |
|-----|-----------------|----------|-----|------------------|----------|
| ① | User Manual | 1 | ④ | Drain Pipe | 1 |
| ② | Rubber Blanket | 4 | ⑤ | Water Pipe Joint | 2 |
| ③ | Drain Connector | 1 | | | |

2.2. Dimensions of the Unit

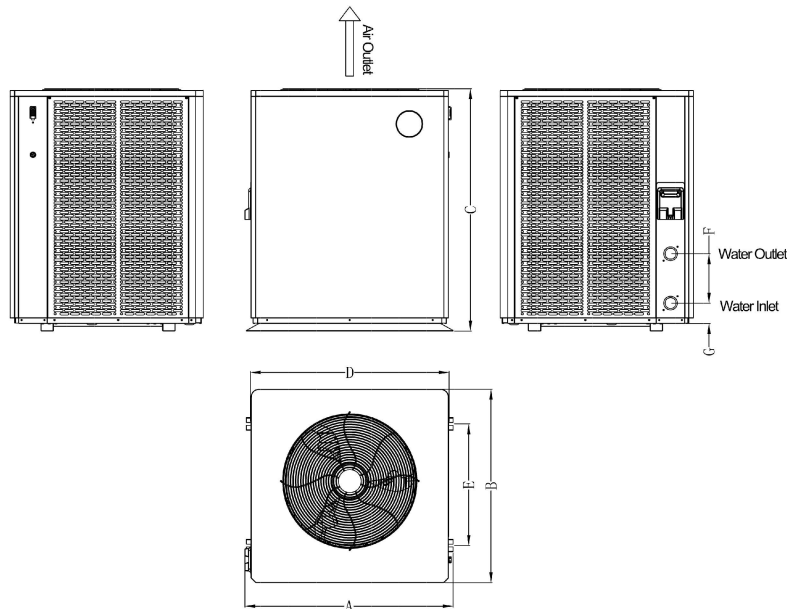

Dimension Unit : (mm)

| Model | A | B | C | D | E | F | G |
|----------------------|-----|-----|------|-----|-----|-----|----|
| HI 85 Top Discharge | 800 | 742 | 783 | 760 | 438 | 380 | 73 |
| HI 110 Top Discharge | 800 | 742 | 965 | 760 | 438 | 180 | 88 |
| HI 140 Top Discharge | 907 | 842 | 1052 | 865 | 538 | 215 | 88 |

2.3. Main Parts of the Unit

HI 85 top discharge
 HI 110 top discharge
 HI 140 top discharge

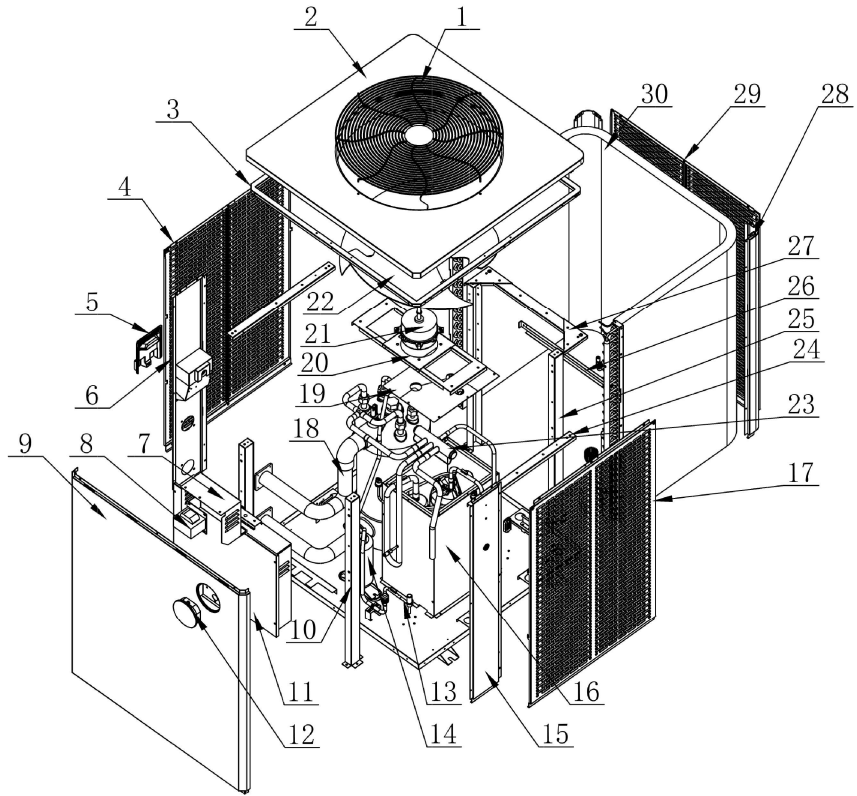

| | | | | | |
|----|-------------------------|----|------------------------------|----|-------------------------|
| 1 | Mesh Cover | 11 | Electrical Box | 21 | Fan Motor |
| 2 | Top Cover | 12 | Wire Controller | 22 | Fan Blade |
| 3 | Top Frame | 13 | Throttling Device Assembly | 23 | 4-Way Valve Assembly |
| 4 | Left Plate | 14 | Liquid Reservoir | 24 | Left/Right Crossbeam |
| 5 | Transition Pipe Handle | 15 | Right Column | 25 | Back Left/Right Column |
| 6 | Left Column | 16 | Compressor Compartment | 26 | Column Fixing Strip |
| 7 | Fixing Plate | 17 | Right Plate | 27 | Column Triangular Plate |
| 8 | Reactor | 18 | Titanium Heat Exchanger | 28 | Back Column |
| 9 | Front Plate | 19 | Compressor Compartment Cover | 29 | Back Plate |
| 10 | Front Left/Right Column | 20 | Motor Support | 30 | Fin Heat Exchanger |

2.4 Parameter of the Unit

| Model | Hi 85 | Hi 110 | Hi 140 |
|--|--------------------------|----------------|----------------|
| Power supply | 220-240V~/50Hz | 220-240V~/50Hz | 220-240V~/50Hz |
| Heating Condition #1 : Ambient 27°C/24.3°C, Inlet/Outlet: 26/28°C, Humidity 80% | | | |
| Heating Capacity (kW) | 4.77~21.60 | 7.06~30.80 | 10.43~40.09 |
| Power Input (kW) | 0.32~3.17 | 0.48~5.06 | 0.69~6.64 |
| COP | 14.91~6.80 | 14.71~6.09 | 15.12~6.04 |
| Heating Condition #2 : 15°C/12°C, Inlet/Outlet: 26/28°C, Humidity 70% | | | |
| Heating Capacity (kW) | 3.43~15.04 | 5.08~20.94 | 7.30~28.20 |
| Power Input (kW) | 0.48~2.85 | 0.71~4.40 | 1.04~6.22 |
| COP | 7.15~5.26 | 7.15~4.76 | 7.02~4.53 |
| Ambient Temperature: (DB/WB) 35°C/~; Water Inlet/Outlet Temperature: 30°C/28°C | | | |
| Cooling Capacity (kW) | 13 | 15.5 | 20.15 |
| Consumed Power (kW) | 3.42 | 4.39 | 5.76 |
| EER | 3.8 | 3.53 | 3.5 |
| Heating temp. range | | 15~40 | 15~40 |
| Operating range | | -10~43 | -10~43 |
| Max power input (kW) | 4.1 | 6.2 | 9.8 |
| Max current (A) | 22 | 27 | 47 |
| Water flow (m ³ /h) | 9 | 13.2 | 17.6 |
| Water Pressure Drop(max.) (kPa) | 30 | 40 | 70 |
| Air side heat exchanger | Hydrophilic fin and tube | | |
| Water side heat exchanger | Titanium PVC Tank | | |
| Refrigerant type / weight(kg) | R32/1.40 | R32/2.10 | R32/4.00 |
| Net Dimensions (mm) | 800×742×783 | 800×742×965 | 907×842×1052 |
| Water pipe connection (mm) | 40mm PVC | 40mm PVC | 40mm PVC |
| Net weight (kg) | 94 | 108 | 146 |
| Sound Pressure level at 1m dB(A) | 56 | 58 | 60 |
| Max./Min. Water operating pressure (MPa) | 0.6/0.1 | 0.6/0.1 | 0.6/0.1 |
| Max./Min. Water inlet pressure (MPa) | 0.6/0.1 | 0.6/0.1 | 0.6/0.1 |

3. INSTALLATION AND CONNECTION

⚠ WARNING: The heat pump must be installed by a professional team. The users are not qualified to install by themselves, otherwise the heat pump might be damaged and risky for users' safety.

This section is provided for information purposes only and must be checked and adapted if necessary according to the actual installation conditions.

3.1 Notice Before Installation

1. The inlet and outlet water unions can't bear the weight of soft pipes. The heat pump must be connected with hard pipes!

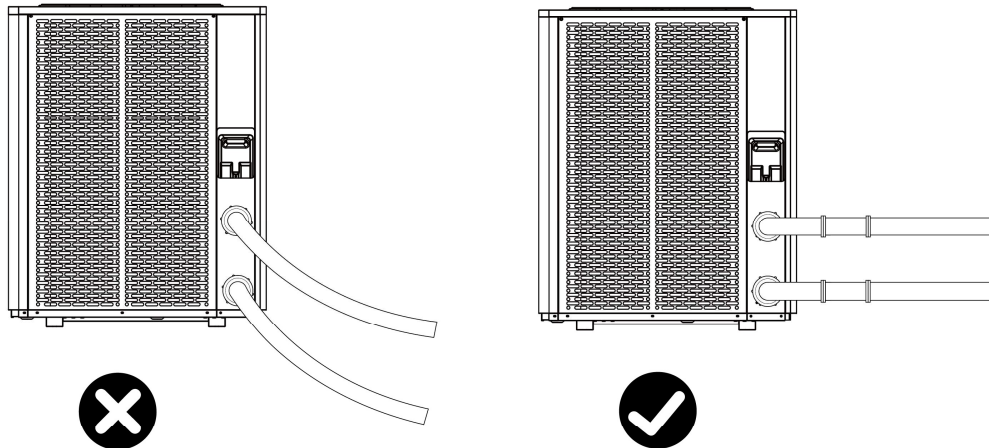

2. In order to guarantee the heating efficiency, the water pipe length should be $\leq 10\text{m}$ between the pool and the heat pump.

3.2 Installation Instruction

3.2.1 Pre-installation

Equipment necessary for the installation of your heat pump:

- ① Power supply cable suitable for the unit's power requirements.
- ② A By-Pass kit and an assembly of PVC tubing suitable for your installation as well as pvc primer & pvc solvent, PVC adhesive and sandpaper.
- ③ A set of wall plugs and expansion screws suitable to attach the unit to your support.
- ④ Suitable fastening studs may be used to raise the unit.

3.2.2 Installation The Heat Pump

- ① The unit can be fixed by bolts (M10) to concrete foundation or brackets. The concrete foundation must be solid; the bracket must be strong enough and anti-rust treated;
- ② The heat pump needs a water pump (Supplied by the user). The recommended pump specification-flux: refer to Technical Parameter, Max. lift $\geq 10\text{m}$;
- ③ When the heat pump is running, there will be condensation water discharged from the bottom, please pay attention to it. Please insert the drainage tube (accessory) into the hole and clip it well, then connect a pipe to drain off the condensation water. Install the heat pump, raising it at least 10 cm with solid water-resistant pads, then connect the drainage pipe to the opening located under the pump.

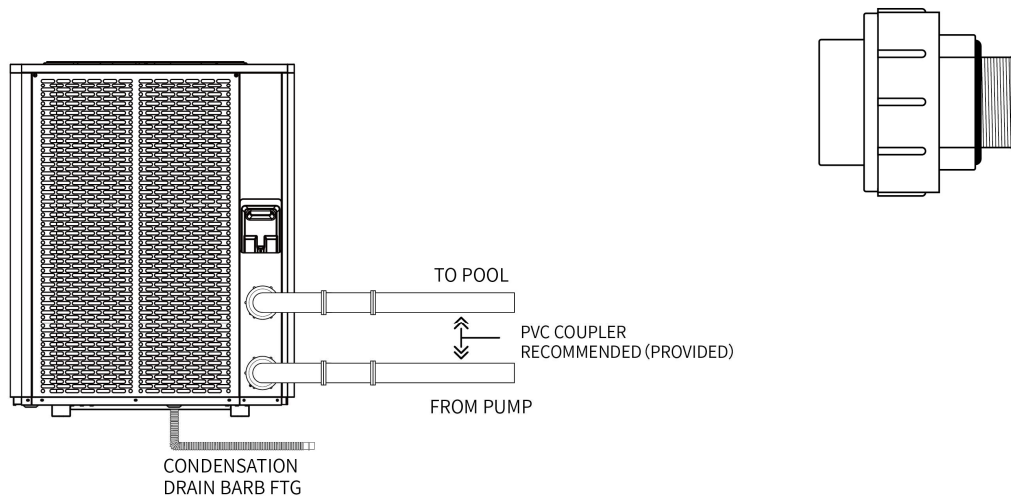

- ④ There are two methods to fixed heat pump chassis.

Method 1: Sheet metal foot fixed.

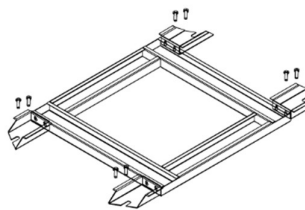

Method 2: Rubber blanket fixed.

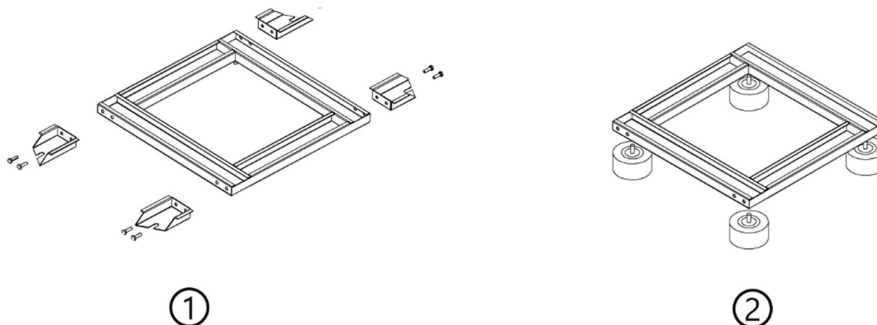

3.2.3 Location and Space

Please comply with the following rules concerning the choice of heat pump location.

- ① The unit's future location must be easily accessible for convenient operation and maintenance.
- ② It must be installed on the ground, fixed ideally on a level concrete floor. Ensure that the floor is sufficiently stable and can support the weight of the unit.
- ③ A water drainage device must be provided close to the unit in order to protect the area where it is installed.
- ④ If necessary, the unit may be raised by using suitable mounting pads designed to support its weight.
- ⑤ Check that the unit is properly ventilated, that the air outlet is not facing the windows of neighbouring buildings and that the exhaust air cannot return. In addition, provide sufficient space around the unit for servicing and maintenance operations.
- ⑥ The unit must not be installed in an area exposed to oil, flammable gases, corrosive products, sulphur compounds or close to high frequency equipment.
- ⑦ To prevent mud splashes, do not install the unit near a road or track.
- ⑧ To avoid causing nuisance to neighbors, make sure the unit is installed so that it is positioned towards the area that is least sensitive to noise.
- ⑨ Keep the unit as much as possible out of the reach of children.
- ⑩ Installation space:

Unit: mm

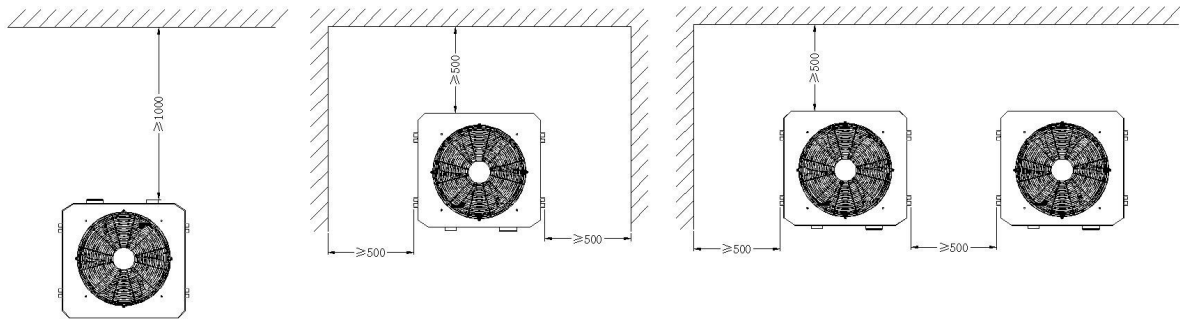

Do not put anything less than one meter in front of the heat pump.

Leave 500 mm of empty space on the sides and back of the heat pump and free ventilation above.

Do not leave any obstacles on the device!

3.2.4 Installation Layout

Notice: The filter must be cleaned regularly to ensure that water in the system is clean and avoid blocking of filter. It is necessary that drainage valve is fixed on the lower water pipe. If the unit is not running during winter months, please disconnect power supply and let out drain water from unit through drainage valve. If ambient temperature of running unit is below 0°C, please keep water pump running.

The installation diagram is shown in the following figure:

An adjustable 3 way valve will be plumbed on the inlet to ensure pool water can be bi passed to the outlet line of the heat pump. This enables the water flow through the heat pump to be adjusted and achieve a 1.5 to 2 degree C rise across the heat pump. Chlorinator cell, chemical dosing of any kind must be installed after the heat pump on the return line to the swimming pool.

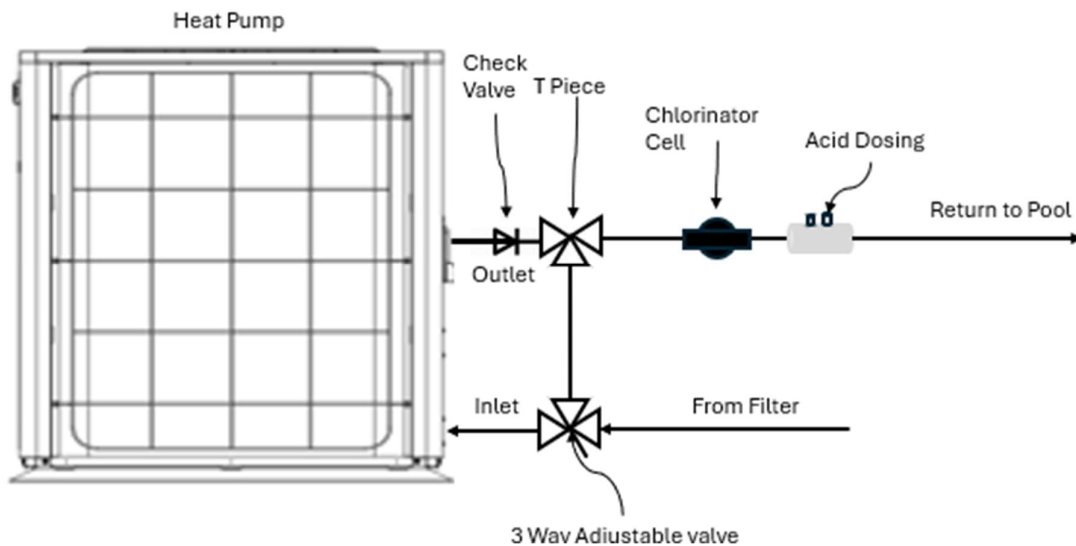

3.2.5 Electrical Installation

To function safely and maintain the integrity of your electrical system, the unit must be connected to a general electricity supply in accordance with the following regulations:

- ① Upstream, the general electricity supply must be protected by a 30mA differential switch.
- ② The heat pump must be connected to the appropriate D-curve circuit breaker in accordance with the prevailing standards and regulations in the country where it is installed.
- ③ The electricity supply cable must be adapted to match the unit's rated power and the length of wiring required by the installation. The cable must be suitable for outdoor use.
- ④ For a three-phase system, it is essential to connect the phases in the correct sequence. If the phases are inverted, the heat pump's compressor will not work.
- ⑤ In places open to the public, it is mandatory to install an emergency stop button close to the heat pump.

| Model | Power Supply Wires | | |
|--------|--------------------|---------------------|----------------|
| | Electricity Supply | Cable Diameter | Specific ation |
| HI 85 | 220-240V~/50Hz | 3G 4mm ² | AWG 12 |
| Hi 110 | 220-240V~/50Hz | 3G 6mm ² | AWG 10 |
| Hi 140 | 220-240V~/50Hz | 3G 6mm ² | AWG 8 |

HI 85/Hi 110 Single Phase

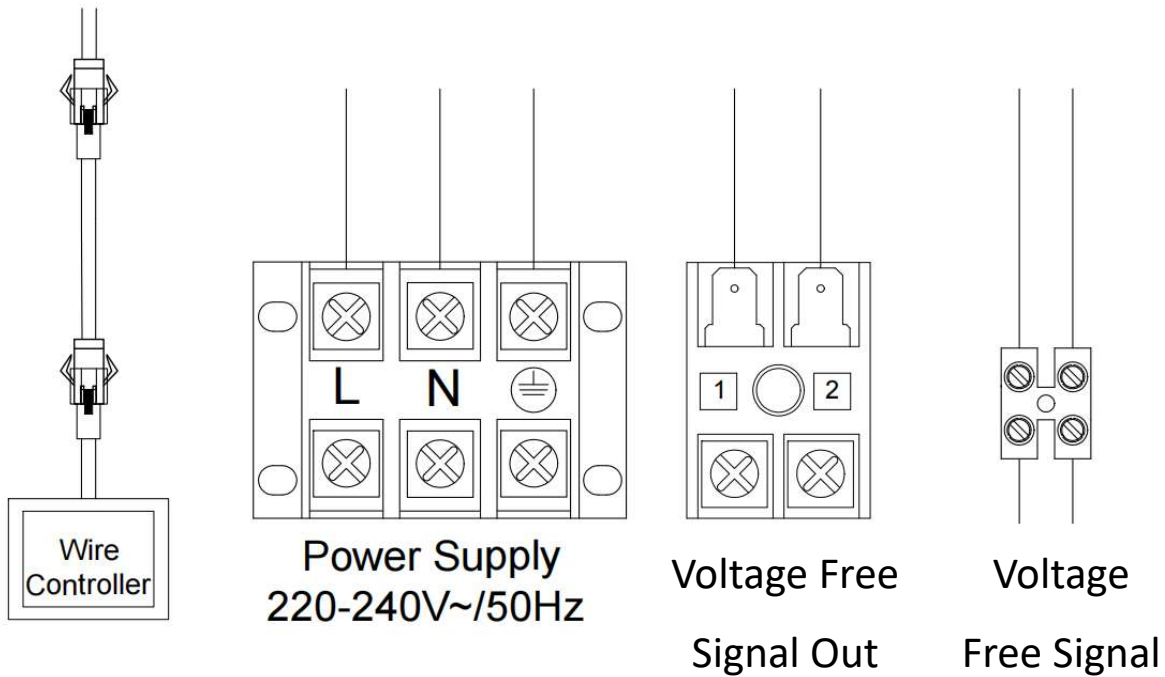

Hi 140 3 phase

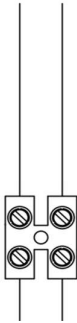
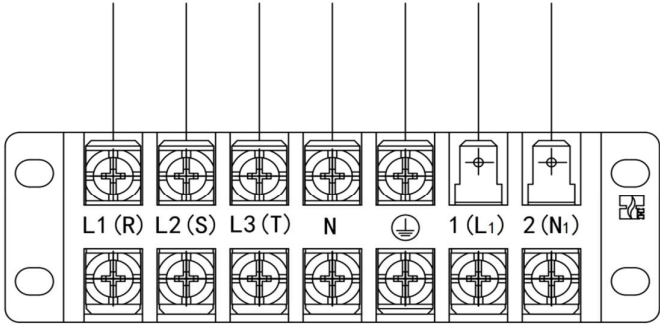
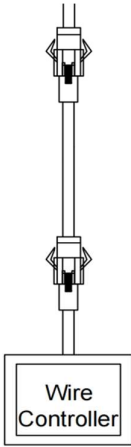

Power Supply
380-415V/3N~/50+

Voltage Free
Signal Out

Voltage
Free Signal

3.1. Trial After Installation

 **WARNING:** Please check all the wiring carefully before turning on the heat pump.

3.4.1 Inspection Before Trial Running

Before running test, confirm below items and write √ in block;

| | |
|--------------------------|--|
| <input type="checkbox"/> | Correct unit installation |
| <input type="checkbox"/> | Power supply voltage is the same as unit rated voltage |
| <input type="checkbox"/> | Correct piping and wiring |
| <input type="checkbox"/> | Air inlet & outlet port of unit is unblocked |
| <input type="checkbox"/> | Drainage and venting is unblocked and no water leaking |
| <input type="checkbox"/> | Leakage protector is working |
| <input type="checkbox"/> | Water Flow is operating and directed through heat pump |
| <input type="checkbox"/> | Ground wire is connected correctly |

3.4.2 Trial Running

Step 1:Running test can begin after completing all installation;

Step 2:All wiring and piping should be connected well and carefully checked, then fill water tank with water before power is switched on;

Step 3:Emptying all air within pipes and water tank, press “on-off” button on control panel to run the unit at setting temperature;

Step 4:Items need to be checked during running test:

- ① During initial operation, unit current is normal;
- ② Each function button on control panel is normal;
- ③ Display screen is functional;
- ④ Are there any leakage in the whole heating circulation system;
- ⑤ Condensate drain is unblocked;
- ⑥ Are there any abnormal sound or vibration during running?

3. REMOTE CONTROLLER OPERATION GUIDANCE

4.1. Control Panel Diagram



| No. | Icon | Meaning | Function |
|-----|------|--------------|--|
| 1 | | Power Mode | Point to the maximum for Boost Point to the medium for Smart Point to the minimum for Silent |
| 2 | | Timed On | Always on indicates that the 'timed on' function is currently enabled |
| 3 | | Timed Off | Always on indicates that the 'timed off' function is currently enabled |
| 4 | | Heating Mode | Display in Heating Mode |
| 5 | | Cooling Mode | Always on indicates Cooling Mode. Flashing indicates defrosting. |
| 6 | | Auto Mode | Display in Auto Mode |
| 7 | | WIFI Icon | Flash during connecting the WIFI. Display when the connection is successful. |
| 8 | | Lock Icon | Always on indicates button is locked |
| 9 | | Mode Key 1 | Press the key in the startup state to switch the Cooling/Heating/Auto Mode |
| 10 | | Mode Key 2 | Press the key in the startup state to switch the Boost/Smart/ Silent Mode |
| 11 | | Up Key | Press the key in the startup state to increase the temp. Long press the key, the temp. will quickly increase. |
| 12 | | Down Key | Press the key in the startup state to decrease the temp. Long press the key the temp. will quickly decrease. |
| 13 | | ON/OFF Key | Press ON/OFF key to switch ON/OFF state; Long press key for 3 seconds to lock / unlock the screen; Press ON/OFF key will return to the main interface. |

4.2 Operation instruction

- **Main Interface Display**

When the power is on, the screen will display all icons, followed by display program version then switch to normal interface operation.

- **ON/OFF**

Press  enter startup state.

Power-off interface



Power-on interface



- **Mode Setting**

In startup state, press  to switch Cooling/Heating/Auto Mode.

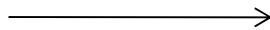

- **Power mode setting**

In startup state, press  to switch Boost / Smart / Silent Mode.

Silent Mode





Smart Mode





Boost Mode





- **Set Temp.**

Press  or  to enter temperature setting interface, the temperature area flashes.

Press  or  to set the target temperature and press  to save the settings and return to the main interface.

If no manual confirmation is made during the setting process, it will automatically confirm and exit the setting status after 5 seconds.

- **Celsius/Fahrenheit Degree**

When the unit is in the shutdown state, long press  and  for 3 seconds to switch Celsius/Fahrenheit .





- **Lock/Unlock**

When the screen is locked, press  for 3 seconds to unlock the screen.

When the screen is unlocked, press  for 3 seconds to lock the screen.

The screen will get locked automatically if there is no key operations for over 30 seconds.

- **Status Query**











Long press  for 3 seconds to enter status query interface, press  or  to check the status parameters.

Status query interface









Short press  or continue for 15S without operation to return to the home page automatically.

● Clock Settings







- (1) In the power on/off interface, press and hold the  for more than 3S to enter the clock setting interface
- (2) In the clock setting interface, short press  to enter the clock hour setting interface.
- (3) In the hour setting interface: The hour part flashes and the minute part displays -- -- . Short/long press  or  to modify the current hour setting value, short press  to save the current hour setting value and enter minute setting interface.
- (4) In the minute setting interface: The minute part flashes, short/long press the  or  to modify the current minute setting value, short press the  to save the current minute setting value, and return to the main interface.
- (5) In the clock setting interface, short press  or 15S continuously without any operation, give up the current modification and return to the main interface.
- (6) In the minute setting interface, short press the  or without any operation for 5S, save the current clock modification value and return to the main interface.







● Appointment Setting Interface Timed Appointment Inquiry Interface







- (1) In the main interface, long press the  +  for more than 3S, you can enter the query reservation interface.
- (2) Short press  or  can cycle through the timer 1 on, timer 1 off, timer 2 on, timer 2 off (two timer settings). Timing time and the corresponding timing setting time flashing alternately, if not open timing, the corresponding timing setting time display "--:--".
- (3) Short press the  or no key operation within 15 seconds, return to the main interface.
- (4) In the corresponding timing time query interface, long press the  for 2S and then release it to cancel the timing function of that period.
- (5) In the timing query interface, long press the  for 5S to cancel all timing functions with one key.







Set Reservation Interface

- (1) In the timer reservation interface, short press the  to enter the Timer 1 ON, Timer 1 OFF, System Status
Timer 2 ON, Timer 2 OFF setting interface.

(2) Timer 1 ON setting interface: short press  or  to modify the Timer 1 ON hour setting value, short press  to save the Timer 1 ON hour setting value, enter the Timer 1 ON minute setting value. Short press  or  to modify the Timer 1 ON minute setting value, short press  or no key operation within 5 seconds to save the Timer 1 ON minute setting value and enter the Timer 1 OFF query screen.

(3) Timer 1 OFF setting interface: short press the  or  to modify the Timer 1 OFF hour setting value, short press  to save the Timer 1 OFF hour setting value, and enter the Timer 1 OFF minute setting. Short press  or  to modify the Timer 1 OFF minute setting value, short press  or no key operation within 5 seconds to save the Timer 1 OFF minute setting value and enter the Timing 2 ON query interface.

(4) Timer 2 ON setting interface: short press the  or  to modify the Timer 2 ON hour setting value, short press the  to save the Timer 2 ON hour setting value, enter the Timer 2 ON minute setting. Short press  or  to modify the Timer 2 ON minute setting value, short press  or no key operation within 5 seconds to save the Timer 2 ON minute setting value and enter the Timer 2 OFF query screen

(5) Timer 2 OFF setting interface: short press the  or  to modify the Timer 2 OFF hour setting value, short press the  to save the Timer 2 OFF hour setting value, enter the Timer 2 OFF minute setting. Short press  or  to modify the Timer 2 OFF minute setting value, short press  or no key operation within 5 seconds to save the Timer 2 OFF minute setting value and enter the Timer 1 ON query interface.

(6) In the appointment setting interface, short press the  to cancel the current appointment function and return to the inquiry appointment interface.



(7) If the timed appointment function is not enabled, the corresponding timed appointment screen displays "-- : --"

(8) If the time set for the Timer ON is the same as the time set for the Timer OFF, then this section of timer setting is invalid and will be displayed as "-- : --".



An example is shown below: Timer 1 ON has been set to 12:00. If you set Timer 1 OFF to 12:00 and save it, the final Timer 1 OFF will be displayed as "-- : --".









- **Manual Defrost**

Heating Mode On and meet the premise of forced defrost, long press  and  5S, to enter the forced defrost mode, at this time the motherboard according to the actual situation to determine whether to implement the defrost command.

- **Wi-Fi Function**

When the power is on, the wire controller will enter network contribution state of 3 minutes,  flashes. If there is no network contribution operations in 3 minutes, it will exit network contribution state and  will stop flashing.

Long press  and  for 3 seconds to enter EZ mode,  flashes rapidly.

Long press  and  for 3 seconds to enter AP mode,  flashes slowly.

When Wi-Fi connects successfully,  displays on the screen.

4.3 Operation Parameters

| Code | Description | Unit |
|------|--------------------------------------|------|
| C1 | Press 1 frequency | Hz |
| C2 | Press 2 frequency | Hz |
| C3 | Inlet water temperature | °C |
| C4 | Coil temperature | °C |
| C5 | Exhaust temperature | °C |
| C6 | Return air temperature | °C |
| C7 | Cooling Coil Temperature | °C |
| C8 | Ambient temperature | °C |
| C9 | Water tank temperature | °C |
| C10 | Return water temperature | °C |
| C11 | Outlet temperature | °C |
| C12 | Coil 2 temperature | °C |
| C13 | Exhaust2 temperature | °C |
| C14 | Return air2 temperature | °C |
| C15 | Cooling coil 2 temperature | °C |
| C16 | Reserved 3 temperature | °C |
| C17 | Main valve 1 opening | P |
| C18 | Auxiliary valve 1 opening | P |
| C19 | Main valve 2 opening | P |
| C20 | Auxiliary valve 2 opening | P |
| C21 | High pressure value | Mpa |
| C22 | Low pressure value | Mpa |
| C23 | High pressure saturation temperature | °C |
| C24 | Low pressure saturation temperature | °C |
| C25 | Drive 1-AC voltage | V |
| C26 | Drive 1-AC current | A |
| C27 | Drive 1 - DC bus voltage | V |
| C28 | Drive 1-Compressor phase current | A |
| C29 | Drive 1-IPM module temperature | °C |
| C30 | Drive 1-DC fan 1 speed | rpm |
| C31 | Drive 1-DC fan 2 speed | rpm |
| C32 | Drive 2-AC voltage | V |
| C33 | Drive 2-AC current | A |
| C34 | Drive 2-DC bus voltage | V |
| C35 | Drive 2-compressor phase current | A |
| C36 | Drive 2-IPM module temperature | °C |
| C37 | Drive 2-DC fan speed | rpm |
| C38 | Drive 2-DC fan speed | rpm |
| C39 | Reserved | - |
| C40 | Reserved | - |
| C41 | CRC32-High 4 bits | - |
| C42 | CRC32-low 4 bits | - |
| C43 | Reserved | - |

4.4 Error Code

When unit has errors, the corresponding error codes will display on the screen.

| Fault Code | Name |
|------------|--|
| EE | In and Out Sensor error Stop |
| E01 | Remote controller lost connection |
| E02 | Driver lost connection |
| E03 | AC current protection |
| E04 | AC Voltage protection |
| E05 | DC Voltage Protection |
| E06 | Phase current Protection |
| E07 | IPM over current IPM |
| E08 | DC current Protection |
| E09 | Discharge temperature too high |
| E10 | Outdoor ambient temperature protection |
| E11 | High pressure protection |
| E12 | Low pressure protection |
| E13 | Reserved |
| E14 | Out water too low |
| E15 | Coil temp too high for cooling mode |
| E16 | Out water too high for heating mode |
| E17 | Flow sensor malfunction |
| E18 | High pressure switch protection |
| E19 | Low pressure switch protection |
| E20 | Power supply phase sequence error |
| E21 | Power supply Phase A lost |
| E22 | In and Out temperature difference too high |
| E23 | Ambient temperature too low for heat mode |

| Fault Code | Name |
|------------|---|
| E24 | Ambient temperature too low for cool mode |
| E25 | Inside coil temperature too low |
| E26 | DC-Fan error |
| E27 | Power supply Phase B lost |
| E28 | Power supply Phase C lost |
| E29 | Reserved |
| E32 | Reserved |
| E33 | Reserved |
| E34 | Reserved |
| E35 | Reserved |
| E36 | Reserved |
| E37 | IPM protection IPM |
| E38 | Inverter module protection |
| E39 | Reserved |
| E40 | Reserved |
| E41 | Reserved |
| E42 | Reserved |
| E43 | Reserved |
| E44 | Reserved |
| E45 | Reserved |
| E46 | Reserved |
| E47 | Reserved |
| E48 | Reserved |
| E49 | In sensor error |
| E50 | Coil sensor error |
| E51 | Discharge sensor error |
| E52 | Suction sensor error |

| Fault Code | Name |
|------------|--|
| E53 | Inside coil sensor error |
| E54 | Ambient sensor error |
| E55 | Reserved |
| E56 | Reserved |
| E57 | Out sensor error |
| E63 | High pressure sensor error |
| E64 | Low pressure sensor error |
| D17 | Driver 1 IPM over current |
| D18 | Driver 1 protection(except IPM protection) |
| D19 | Driver 1 over current |
| D20 | Reserved |
| D21 | Reserved |
| D22 | Driver 1 IPM over temperature |
| D23 | Driver 1 PFC Protection |
| D24 | Driver 1 DC Voltage too high |
| D25 | Driver 1 DC voltage too low |
| D26 | Driver 1 AC voltage too low |
| D27 | Driver 1 AC current too high |
| D28 | Reserved |
| D29 | Reserved |
| D30 | Reserved |
| D31 | Reserved |
| D32 | Driver 1 connection error |
| D33 | Driver 1 IPM temperature sensor error |
| D34 | Driver 1 DC fan1 error |
| D35 | Driver 1 DC fan2 error |
| D36 | Driver 1 15V power error |

4.2. Wi-Fi Settings (Not recommended if using Insrnr inTouch App – only use if no other System App is connected)

4.5.1 Software Installation

- ① Method 1: Search "Smart life" in your APP store ,install "".Click "GET" to install.

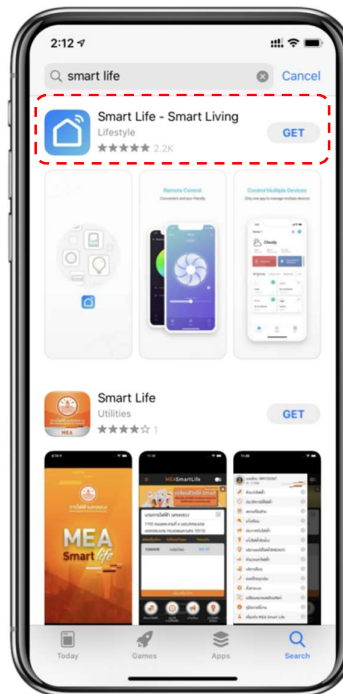



- ② Method 2: Scan the QR code below.







For IOS and Android Users

4.5.2 Software Startup



After installation,click “

4.5.3 Software Registration and Configuration

1. Registration

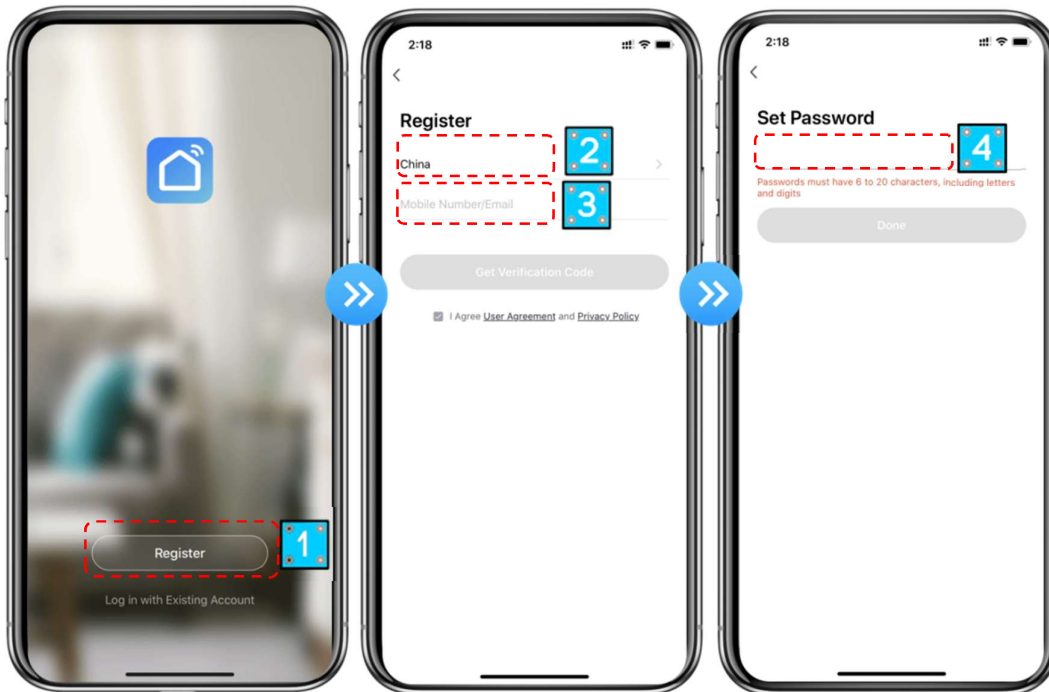
① Users don't have account can click “Register” to create an account: Register  Enter your phone number  Get Verification Code  Enter Verification Code  Set Code;



② After registration, you need to Create a Home:Create a Home  Set Home Name 
Set Home Location  Add Rooms.

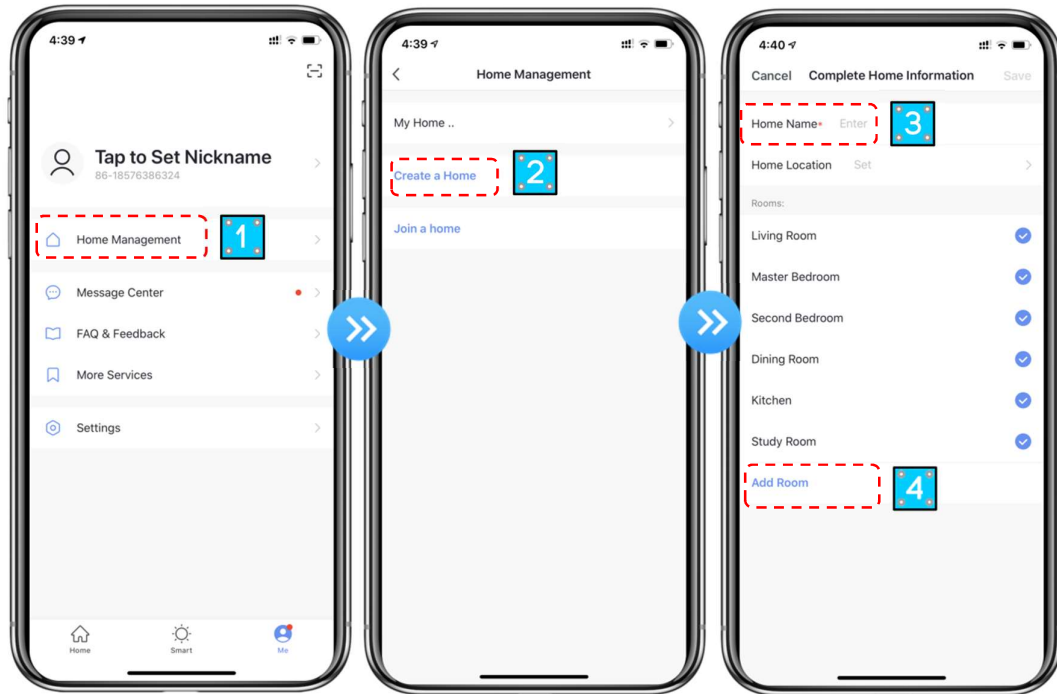

2. Account ID+ Password Login

① Existing accounts can be logged in directly, in the following order.

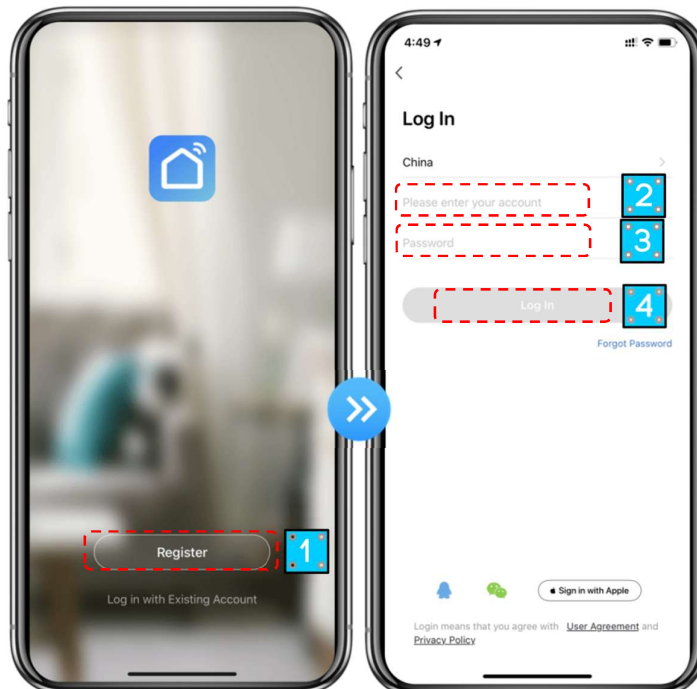

② If you forget your password you can choose to login with your verification code and select "Forget Password": Enter your phone number → Get verification code .

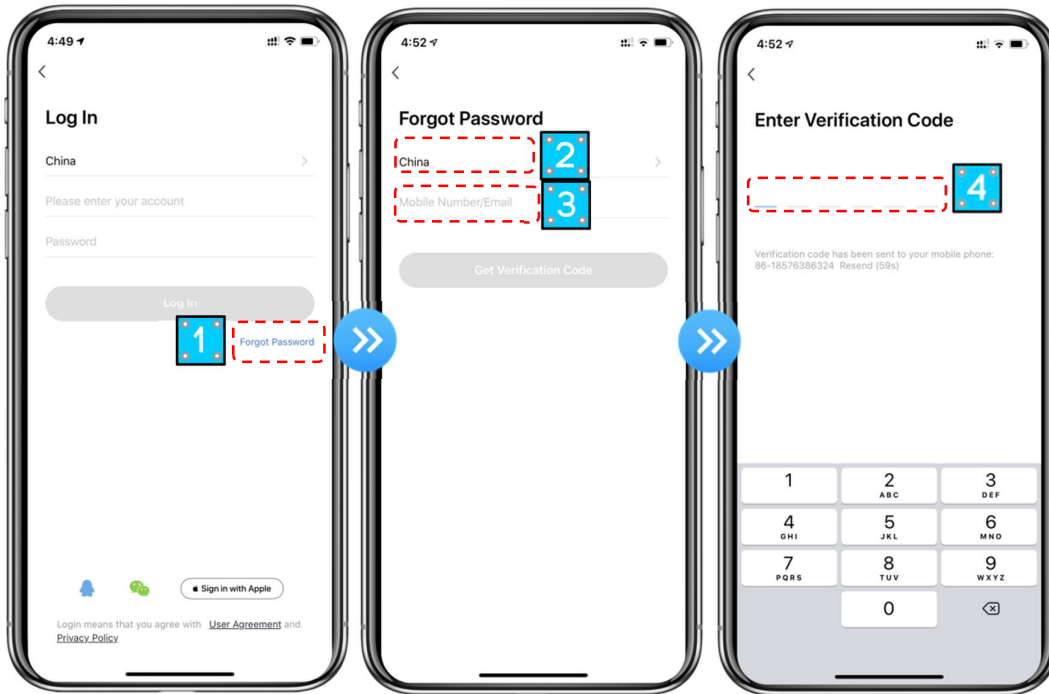

③ After creating a home or logged in, enter the main interface of APP.



Note:

Click the device to check the status, and you can set the operating mode, ON/OFF, timer. Click "+" to add devices.

3. Wi-Fi Module configuration steps:

Method 1

Step 1:

EZ Mode: When power is on, press and hold the "▲+⏻" keys at the same time for 3 seconds

to enter the distribution network. The "📶" icon will flash rapidly;

Step 2:

Turn on the phone's Wi-Fi function and connect to the Wi-Fi hot-spot. The Wi-Fi hot-spot must be able to connect to the Internet normally;

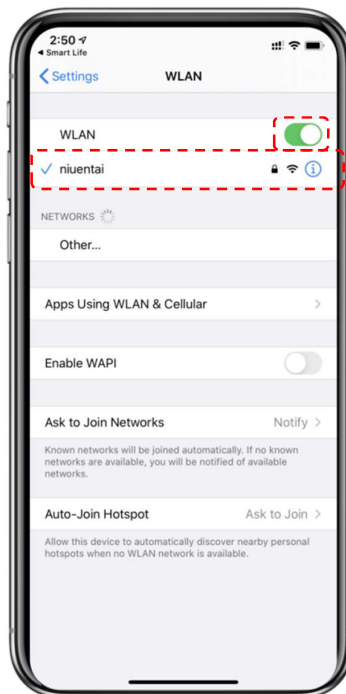

Step 3:

Open the "smart life" APP, log in into the main interface, click on the top right corner "+" or "add equipment" of the interface, enter the equipment type selection, the "Large Home Appliances" , select "Smart Heat Pump" equipment and add equipment into the interface.

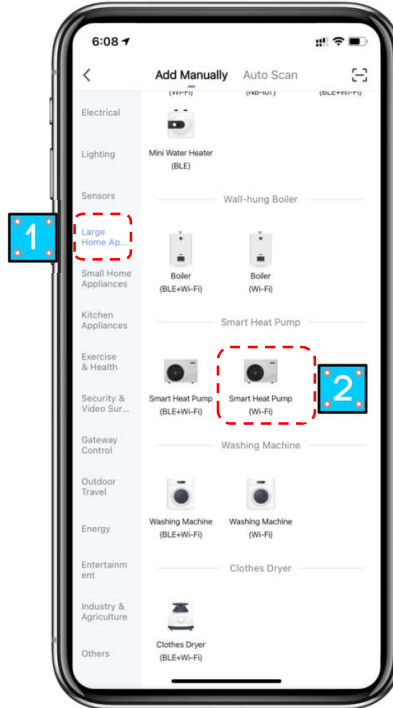

Step 4:

After selecting "Smart Heat Pump", enter the interface of "Add Equipment", and confirm that the wire controller has selected the EZ mode. After the indicator light under "📶" flashes rapidly , click "Confirm indicator rapidly blink ".

Enter the Wi-Fi connection interface, enter the Wi-Fi password of the mobile phone (it must be the same as the Wi-Fi of the mobile phone), click "Next", and then directly enter the connected status of the device.

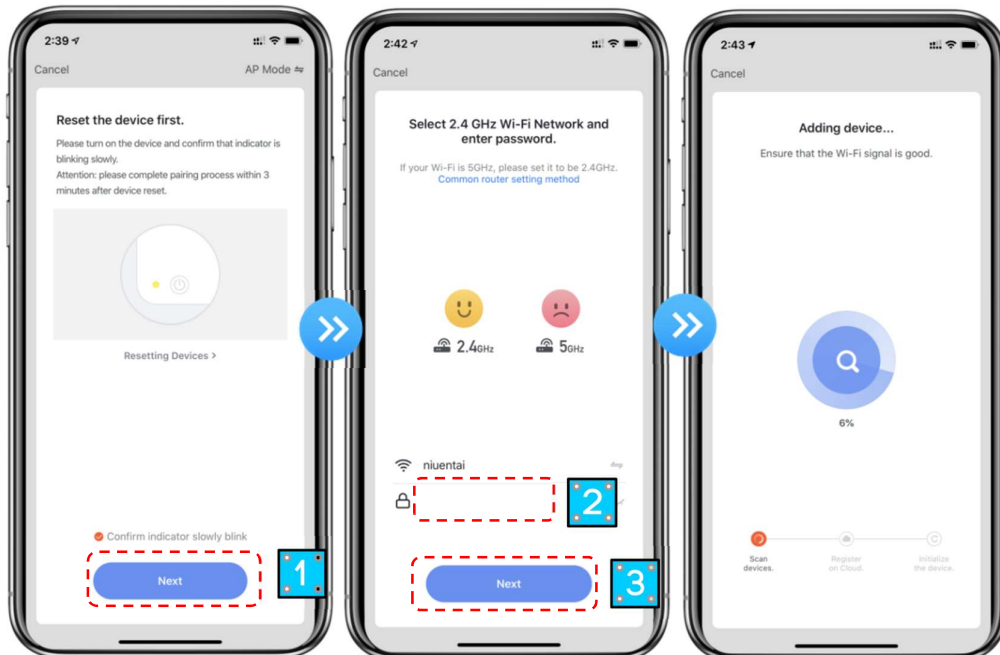

Step 5:

When "Scan devices", "Register on Cloud", "Initialize the device" are all completed, connect succeeds.

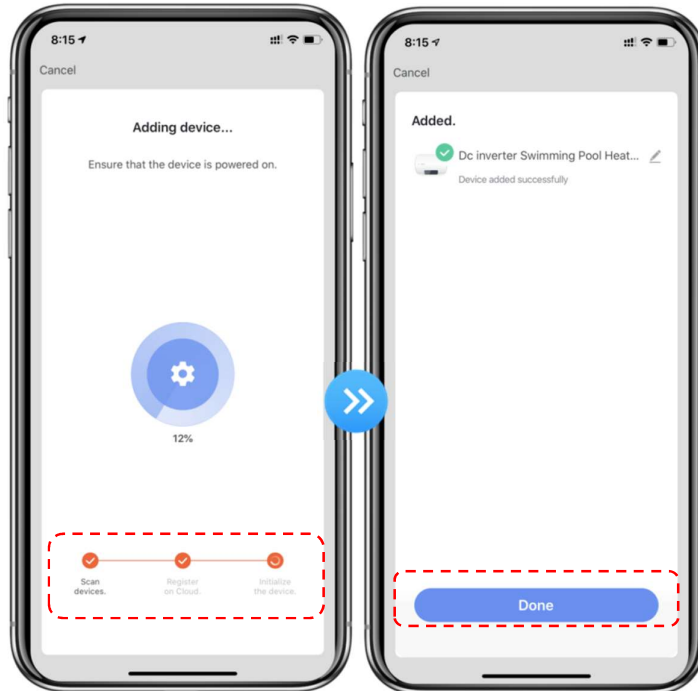

Method 2

Step 1

AP Mode: Press and hold the "▼" + "⏻" keys at the same time for 3 seconds to enter the distribution network. The "📶" icon will flash slowly.

Step 2&3

Same with EZ Mode above.

Step 4

After entering the add device interface, click "EZ Mode" in the upper right corner; Enter the AP mode to add the device interface, confirm that the AP mode has been selected, and click "Confirm indicator slowly blink".

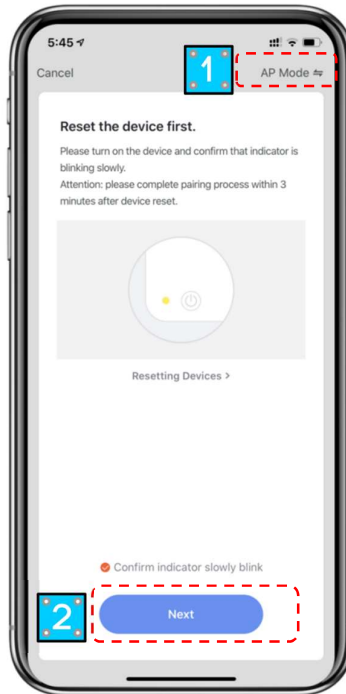

The interface of Wi-Fi connection will pop up, enter the Wi-Fi password of the mobile phone (it must be the same as the Wi-Fi of the mobile phone), click "Next", "Connect your mobile phone to the device's hotspot" will pop up, and click "Go to Connect";

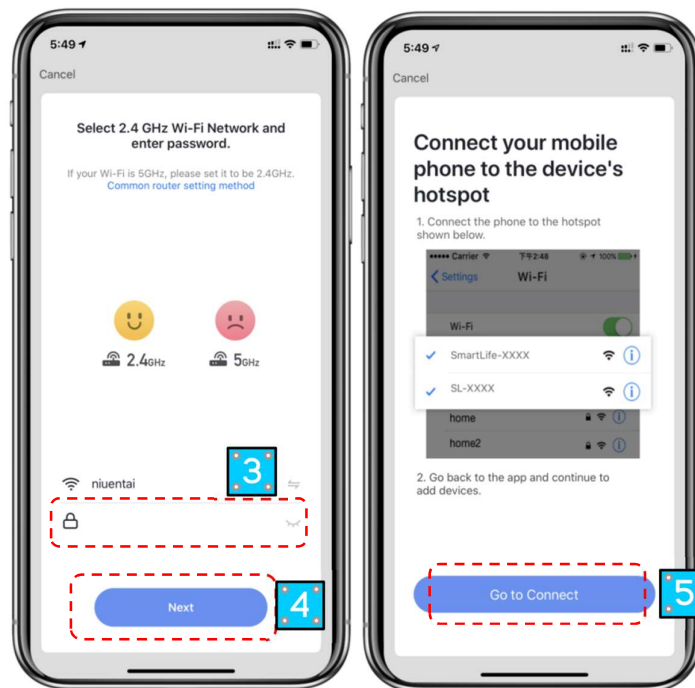

Enter the mobile phone Wi-Fi connection interface, find the "Smart Life_XXXX" connection, and the APP will automatically enter the device connection status.

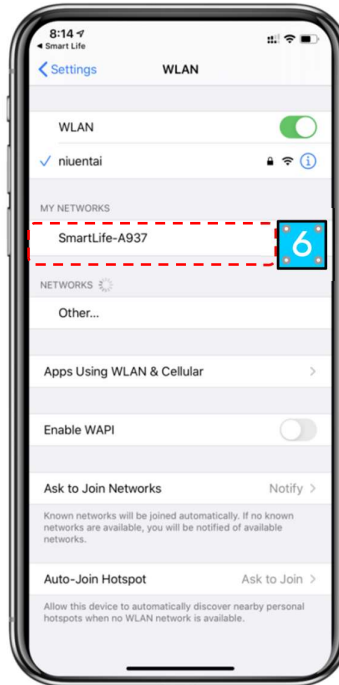

Step 5 : Same as EZ mode above.

Note: If the connection is failed, please enter the AP mode manually and reconnect according to the above steps.

4.5.4 Software Function Operation

- After the device is bound successfully, enter the operation interface of “Smart heat pump” (Device name, modifiable)
- In the main interface of “Smart Life”, click “Smart heat pump” to enter the operation interface.



- ① Back
- ② More: You can change device name, select device installation location, check networking status, add Shared users, create device cluster, view device information, and more.
- ③ Setting temp. adjustment: The circle slides counterclockwise to reduce the temp., but clockwise to increase the temp..
- ④ Target temp.
- ⑤ Current temp.
- ⑥ ON/OFF
- ⑦ Mode switching: Click to select the mode to be switched.
- ⑧ Timing: Click to add timing off/on time.

● **Modify device name**

Click in the following order to enter device details, and click "Device Name" to rename the device.

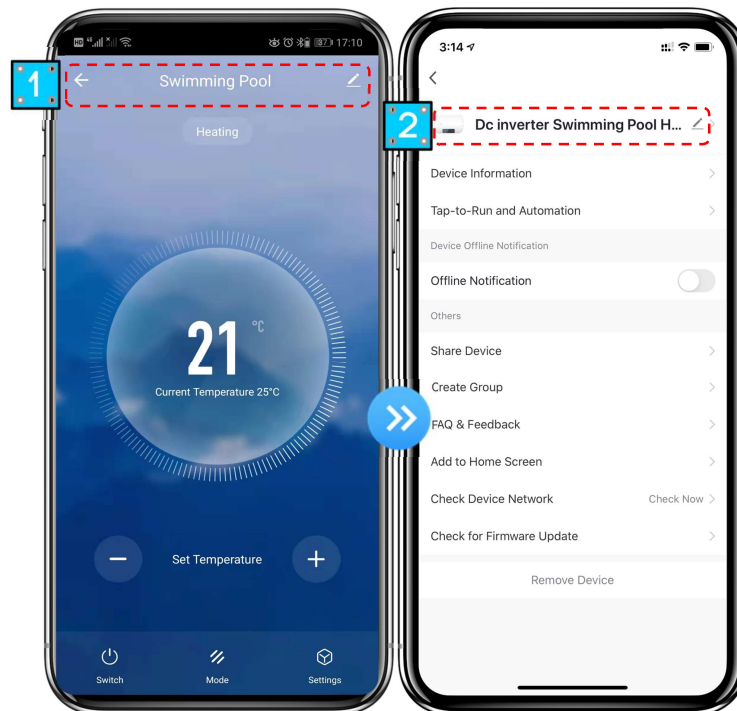

- **Device sharing**

- ◆ To share a bound device, the user should do so in the following order.
- ◆ After successful sharing, the list will be added to show the person shared
- ◆ If you want to delete the account you shared to, cross the selected account to the left, and delete it.
- ◆ The user interface is as follows.

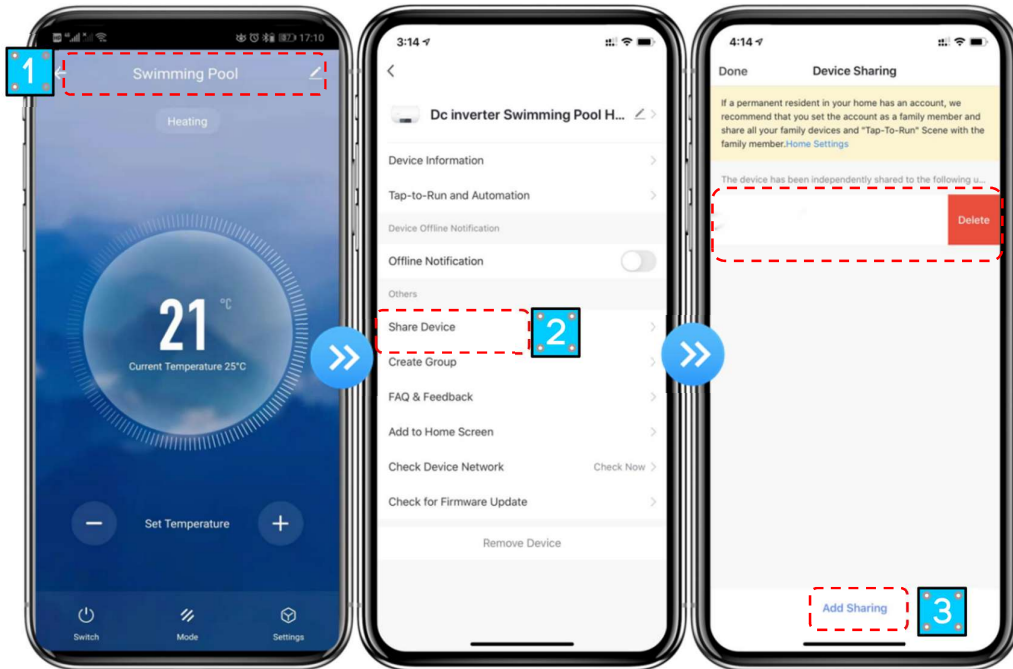

- ◆ Enter the account of the shared, click "Done", and the share success list shows the newly added account of the Shared.

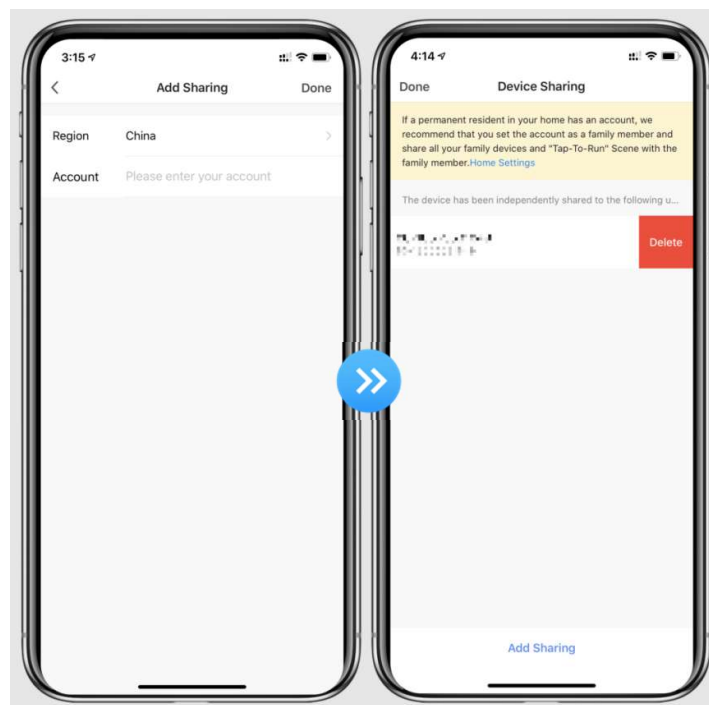

- ◆ The interface of the person to be shared is as follows. The received shared device is displayed. Click it to operate and control the device.



- **Mode settings**

Click “” on the main interface to switch modes, select what you need.

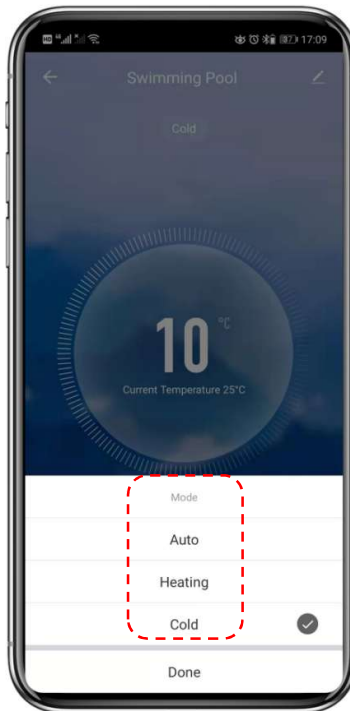

- **Timer setting**

1. Click “” on the main interface to enter timer setting interface, as shown below, click to add timer.

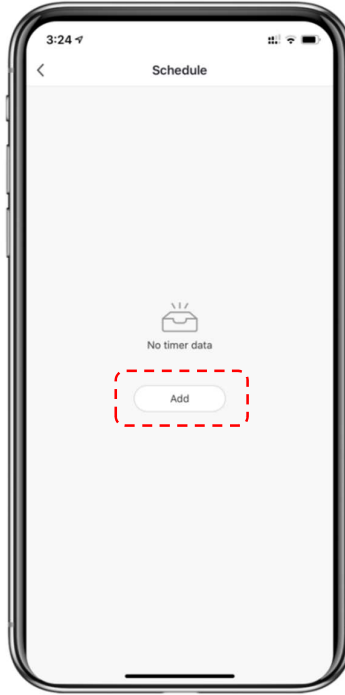

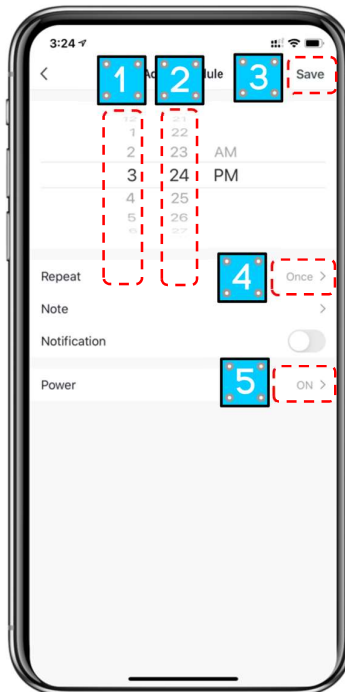

1. After entering timer setting, swipe up/down to set timer, set up repeat weeks and on/off, then click “save” to save your settings as follows.



- ① Hours
- ② Minutes
- ③ Set the repetition
- ④ Set power ON/OFF
- ⑤ Save your modification

4.5.5 Device Removal

Click “” on the top right corner of the main interface to enter the device details interface, and click “device removal” to enter EZ mode. Indicator light under “” flashes rapidly for 3min, The network can be reconfigured within 3 minutes, and the network can be quit if it is not connected within 3 minutes. The specific operations are shown as follows.

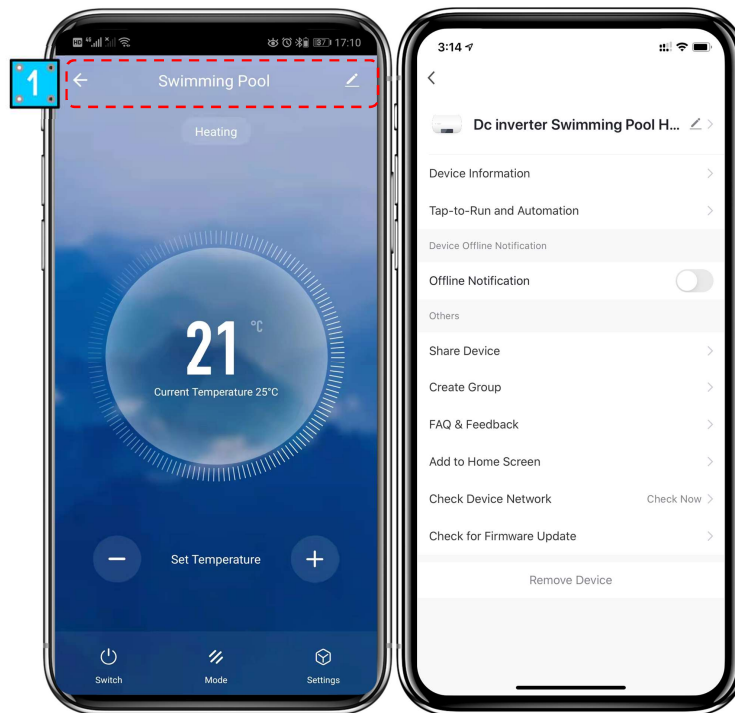

4. MAINTENANCE AND WINTERIZING

5.1. Maintenance

 **WARNING:** Before undertaking maintenance work on the unit, ensure that you have disconnected the electrical power supply.

- **Cleaning**

- a. The heat pump's casing must be cleaned with a damp cloth. The use of detergents or other household products could damage the surface of the casing and affect its properties.
- b. The evaporator at the rear of the heat pump must be carefully cleaned with a vacuum cleaner and soft brush attachment.

- **Annual maintenance**

The following operations must be undertaken by a qualified person at least once a year.

- a. Carry out safety checks.
- b. Check the integrity of the electrical wiring.
- c. Check the earthing connections.
- d. Monitor the state of the pressure gauge and the presence of refrigerant.

5.2. Winterizing

In winter season when you don't swim:

- a. Cut off power supply to prevent any machine damage.
- b. Drain water clear of the machine.

 **“CUT OFF” power supply of the heater before cleaning, examination and repairing**

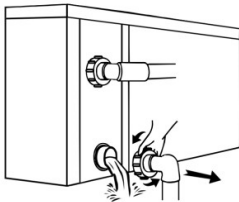

 **!! Important:**

Unscrew the water nozzle of inlet pipe to let the water flow out. When the water in machine freezes in winter season, the titanium heat exchanger may be damaged.

- c. Drainage of chassis condensate.
- d. Cover the machine body when not in use.

WARRANTY

Insnrng products are designed and manufactured to the highest possible standards of performance.

Australian Consumer Law

Our goods come with guarantees that cannot be excluded under the Australian Consumer Law. You are entitled to a replacement or refund for a major failure and for compensation for any other reasonably foreseeable loss or damage. You are also entitled to have the goods repaired or replaced if the goods fail to be of acceptable quality and the failure does not amount to a major failure.

Warranty Period and Conditions:

Insnrng Techne Pty Ltd (herein after “the Company”) is pleased to warrant to the original retail purchaser that this product shall be free of manufacturing defects from the original invoice date subject to the following conditions for the following periods:

| | | |
|------|--|----------|
| I. | Titanium Heat Exchanger Coil: | 25 years |
| II. | Compressor: | 3 years |
| III. | Fan, fan motor, circuit boards and parts | 2 years |
| IV. | Labour | 1 year |

1. The product is purchased new from an authorised Insnrg dealership in Australia.
2. This warranty is not assignable and applies to the original retail purchaser only and the original receipt, invoice or any other proof of purchase must be retained and produced if required by the Company.
3. Nothing in this warranty shall apply to any defects caused by misuse or abuse, neglect, accident, extremes of climate, dampness, humidity, reasonable fair wear and tear and/or any causes other than defects in manufacturing and materials. Proper care and maintenance information is detailed in the Owner’s Manual for this product which you must follow.
4. Where a defect is physically visible or otherwise affects the exterior surfaces of the product, you must notify the Company of such defect within fourteen (14) days from the date of your purchase.
5. If the product is bought as a demonstration, refurbished, ex-rental, discontinued or otherwise previously unboxed unit, the warranty applicable shall be limited to 6 months.

Thanks again for purchasing some of Insnrg's products. We hope that you will consider some of our other Australian Designed and Manufactured Pool and Spa Appliances.

We know that you will get many years of enjoyment from this product.

Insnrg loves to design and manufacture unique, energy-efficient appliances for filtration, treatment and making the swimming and bathing experience a joy. Our hard working pool and spa appliances do require service and maintenance from time to time so please contact us to schedule a service. If you have ideas of how you would like to see your pool or spa operate, please feel free to contact us.

MAIL

57-59 Nantilla Road,
Clayton, VIC, 3168

LANDLINE

(03) 8578 5633

WEBSITE

www.insnrg.com

