

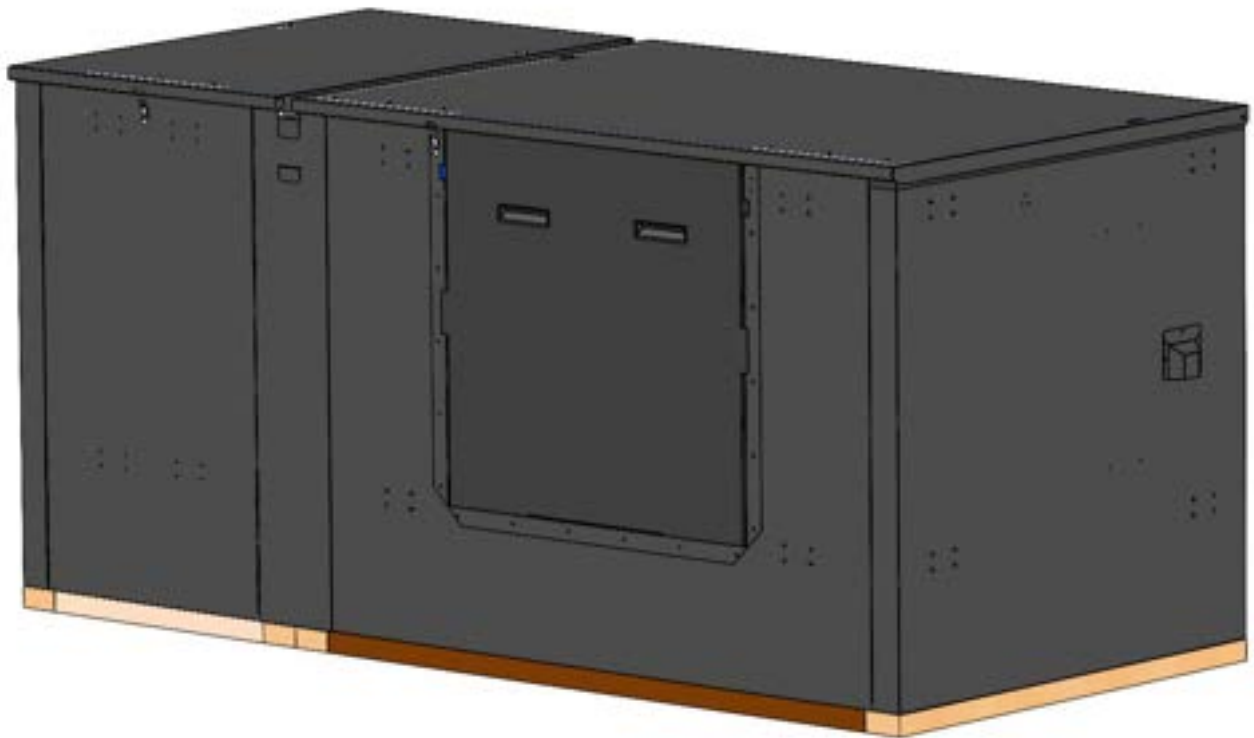











ECHOLOCK 2400



Assembly Procedure



Accessories List

NAME	IMAGE	QUANTITY
Locking assembly: REAR LEFT		4
Locking assembly: REAR RIGHT		4
Locking assembly: FRONT LEFT		4
Locking assembly: FRONT RIGHT		4
Brace: REAR LEFT		3

<p>Brace: REAR RIGHT</p>		<p>3</p>
<p>Brace: FRONT LEFT</p>		<p>3</p>
<p>Brace: FRONT RIGHT</p>		<p>3</p>
<p>GAS STRUTS</p>		<p>2</p>
<p>GAS STRUTS (50N)</p>		<p>2</p>
<p>Hinge Pin</p>		<p>4</p>

Retaining Clip		4
Black bush		2
White Washer		2

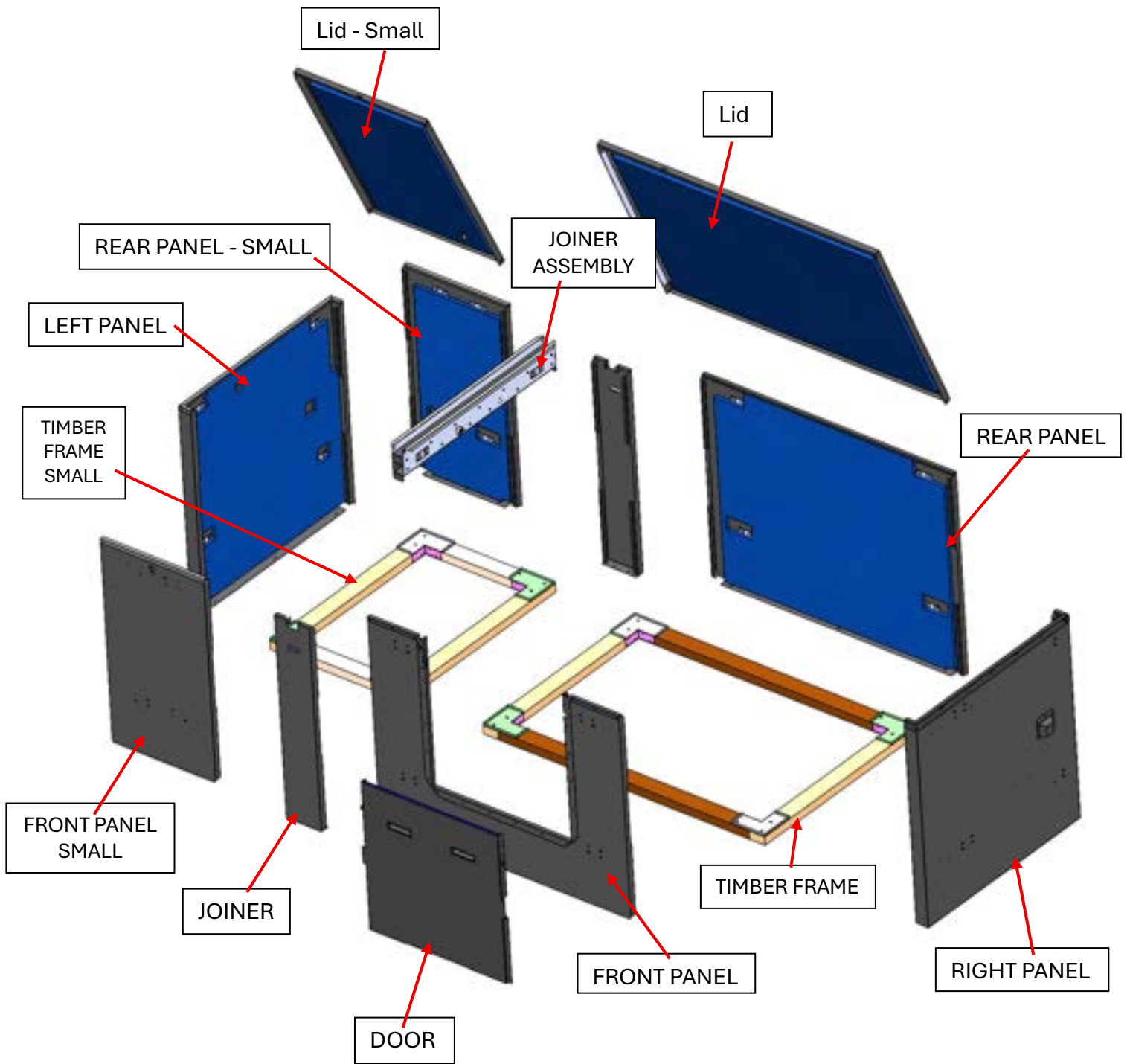

1. Align the Timber frames as shown below

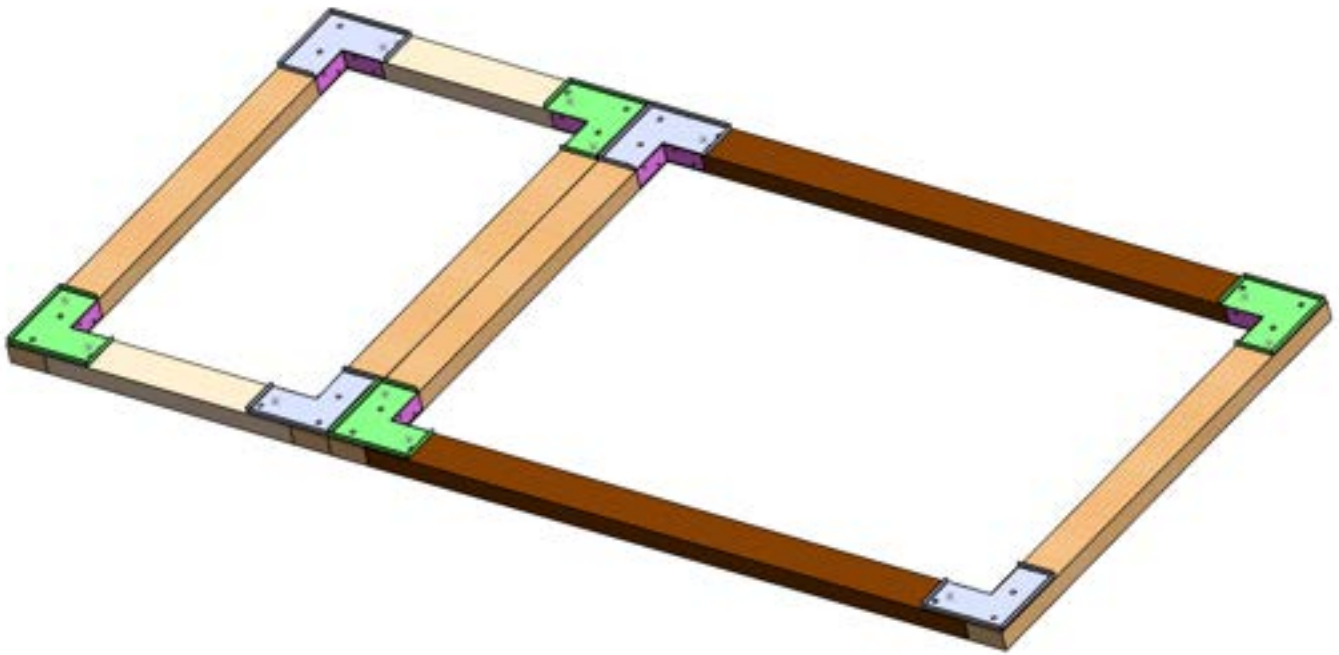

2. Slide in the SMALL Rear panel

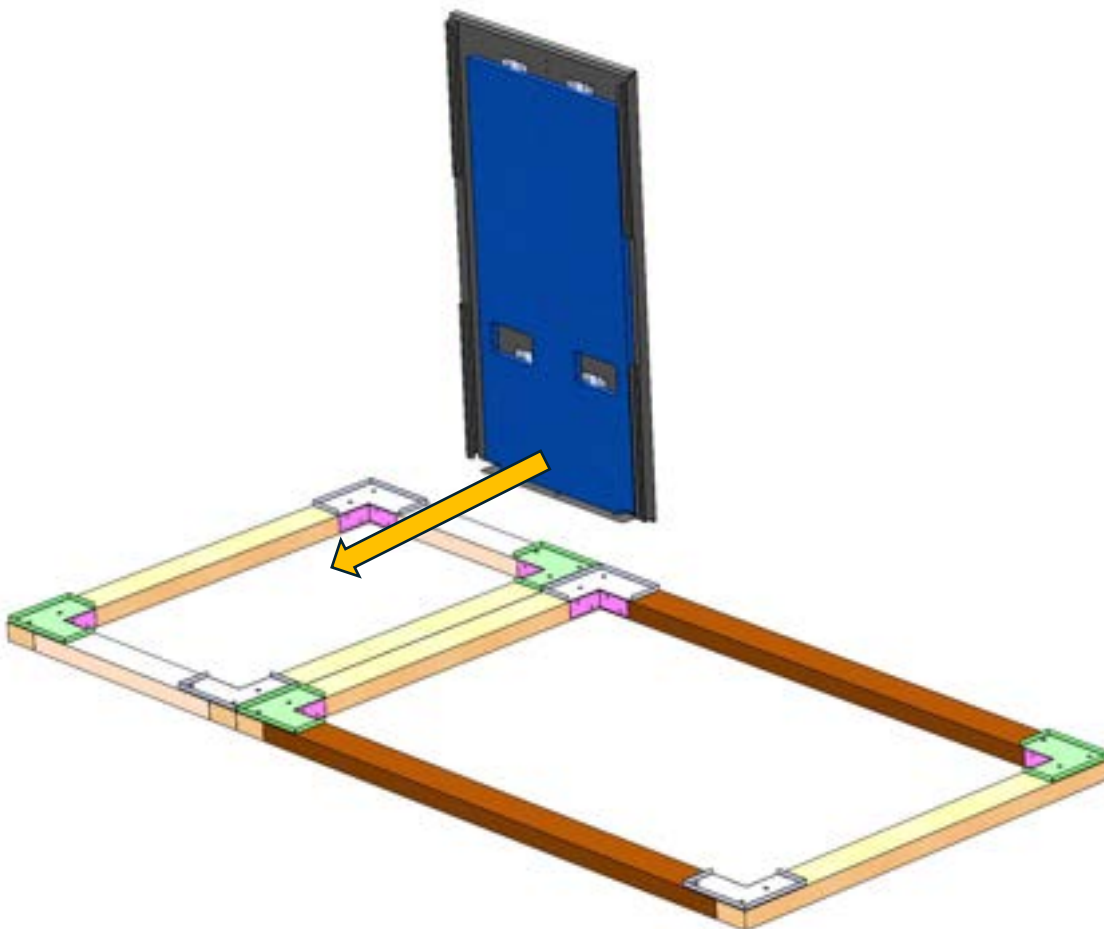

3. Slide in the Left Side panel

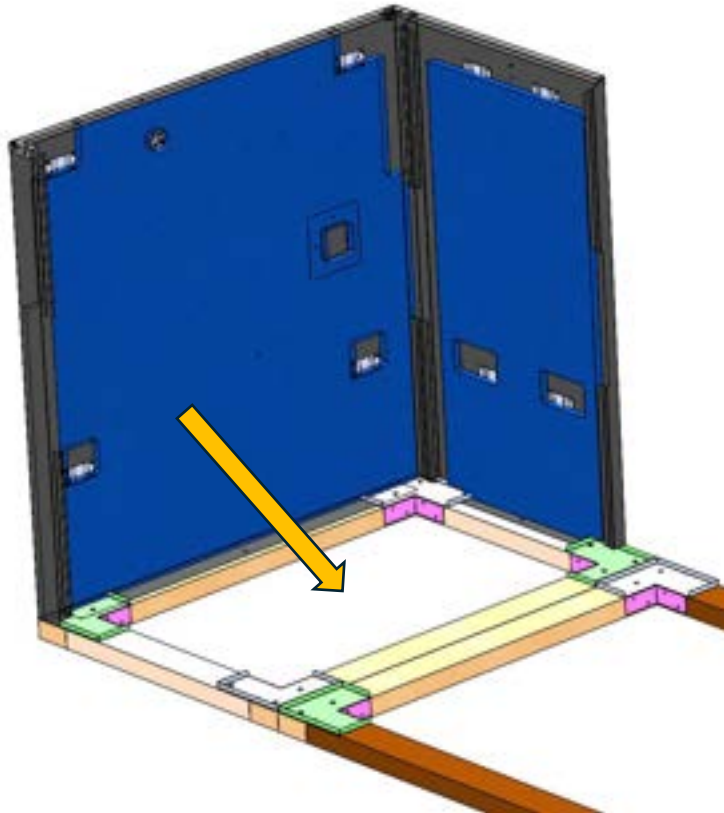

4. Slide the Locking assembly with the “REAR LEFT” label.



5. Repeat step 3 for the bottom locking assembly



6. Fit Brace with "REAR LEFT" label and Push Down.

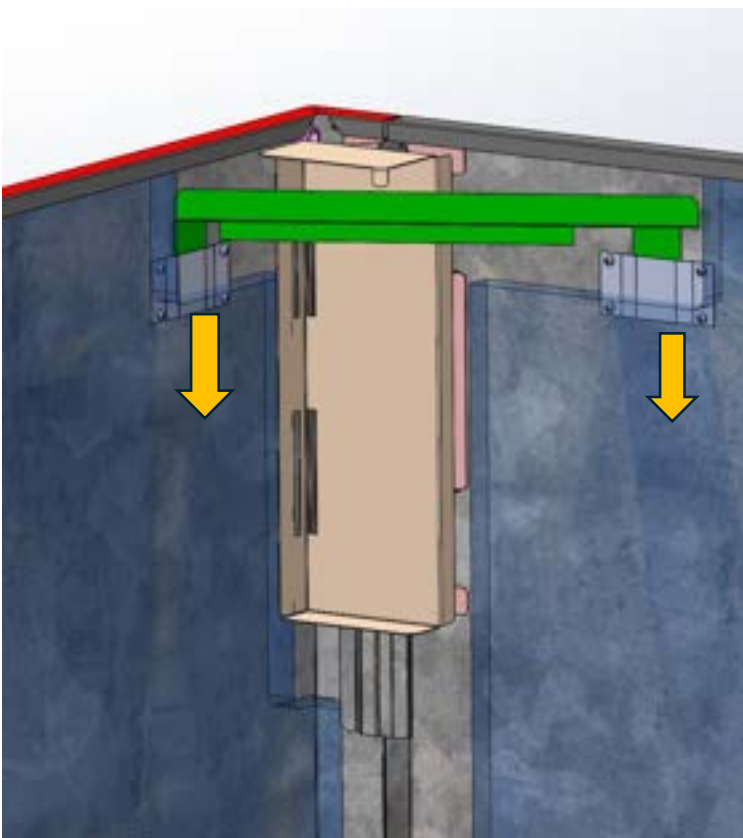

7. Push Locking assembly down to engage with the Brace

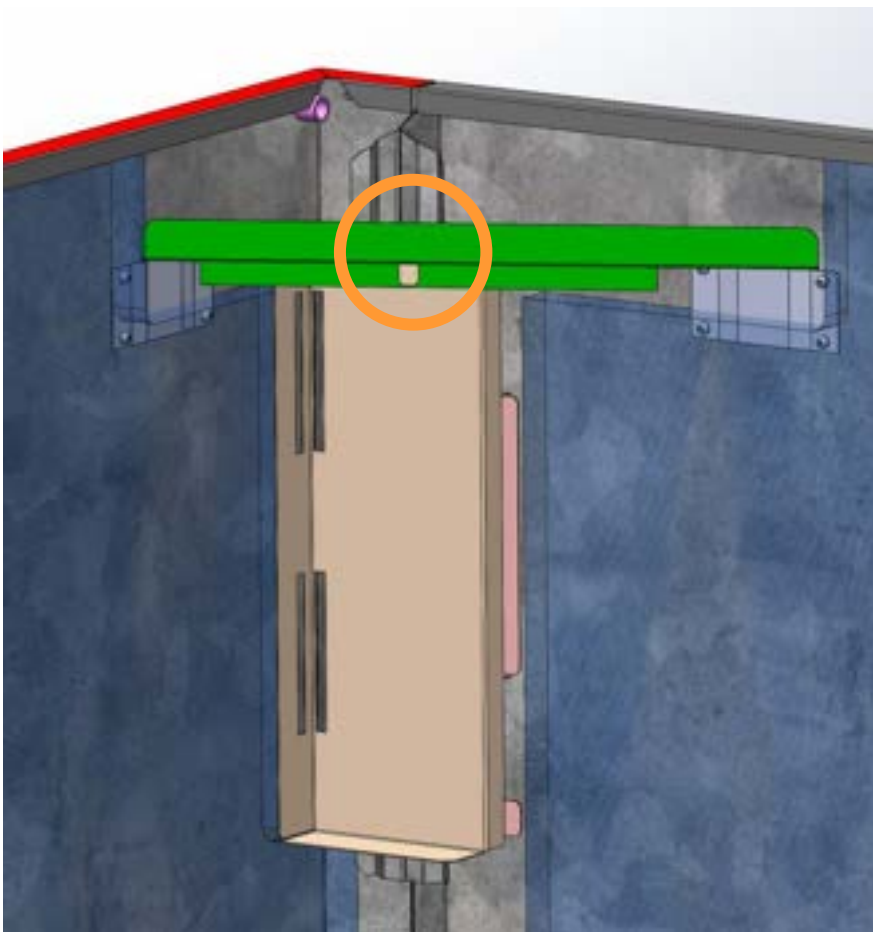
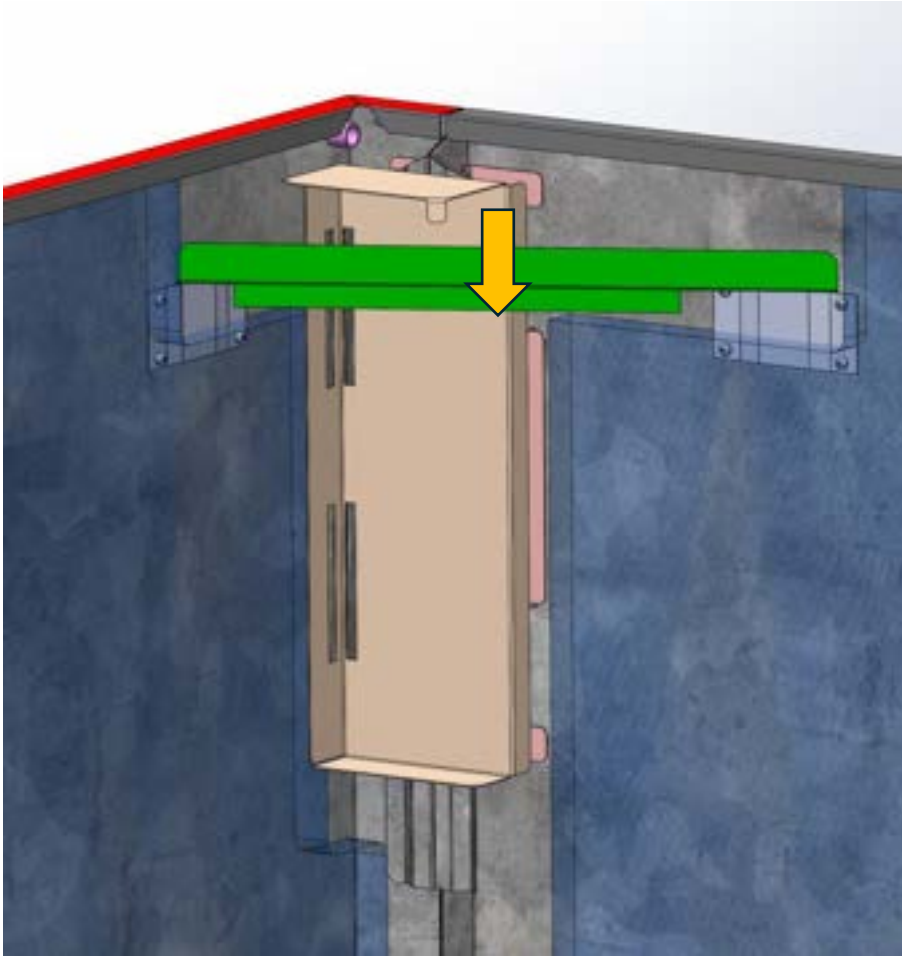

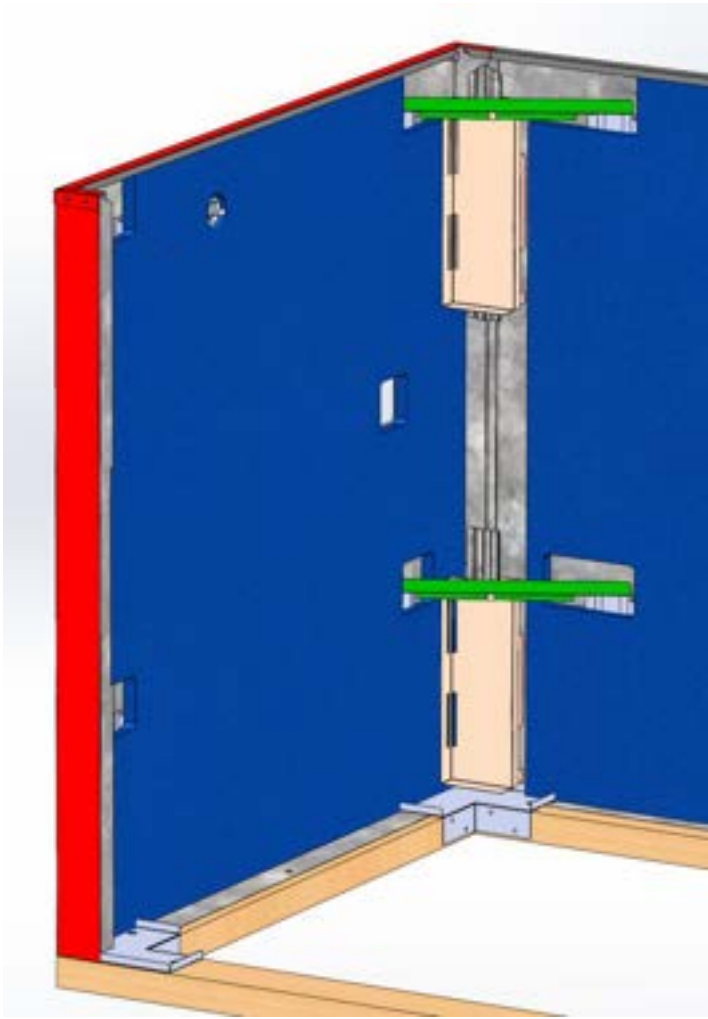

8. Slide in the Joiner next to the Small Rear Panel

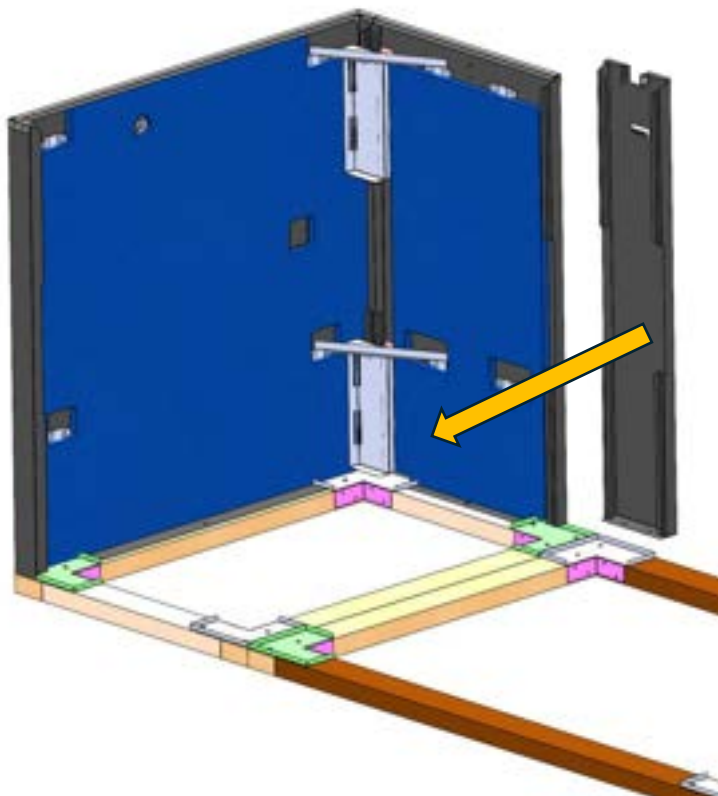

9. Attach the Locking pillars labelled “**REAR RIGHT**”

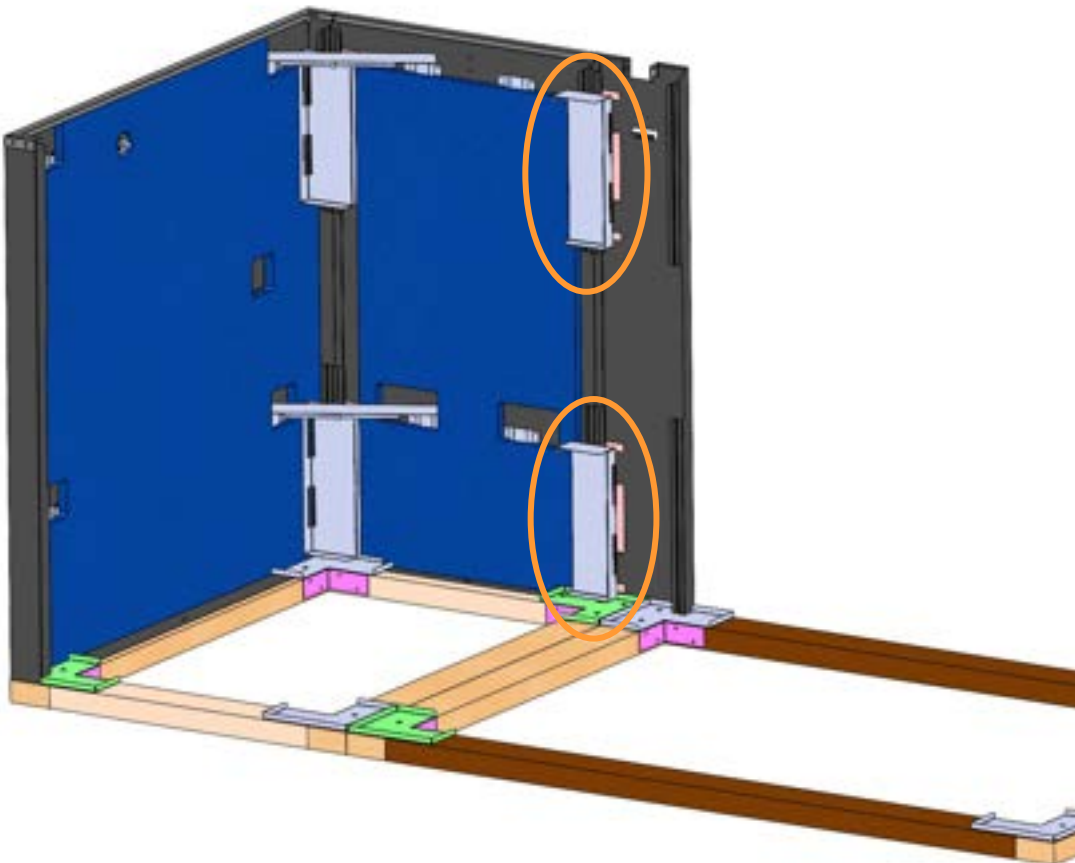

10. Slide in the SMALL Front panel and attach the Locking pillars and brace labelled “**FRONT LEFT**”.

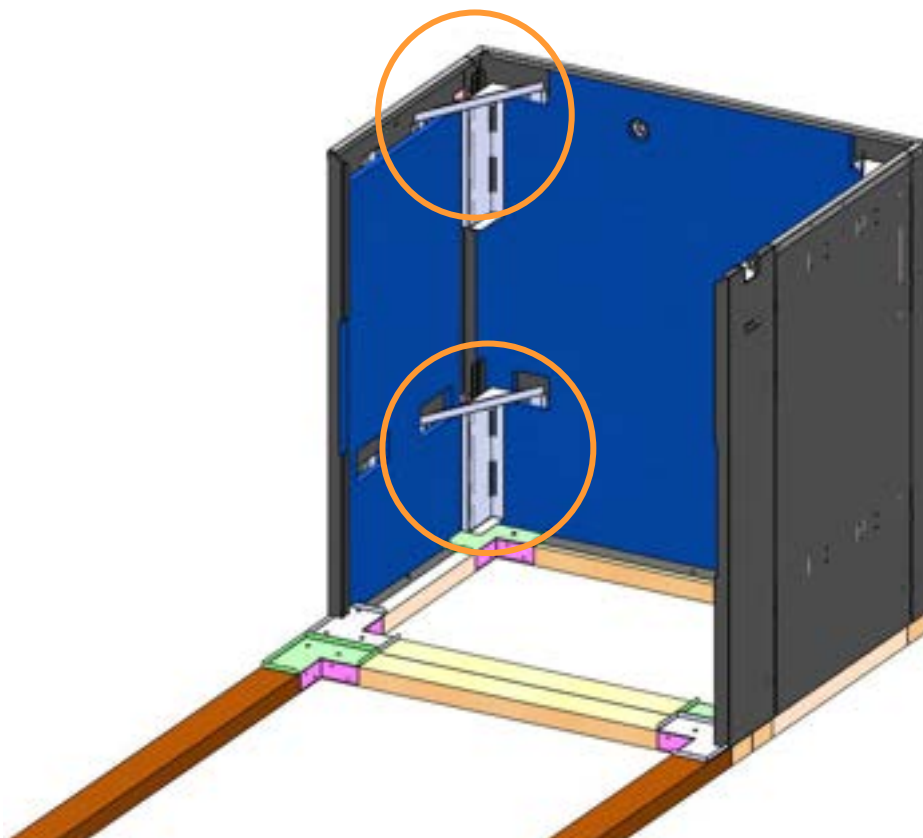

10. Slide in the other joiner next to the front panel and attach the locking pillars labelled **“FRONT RIGHT”**

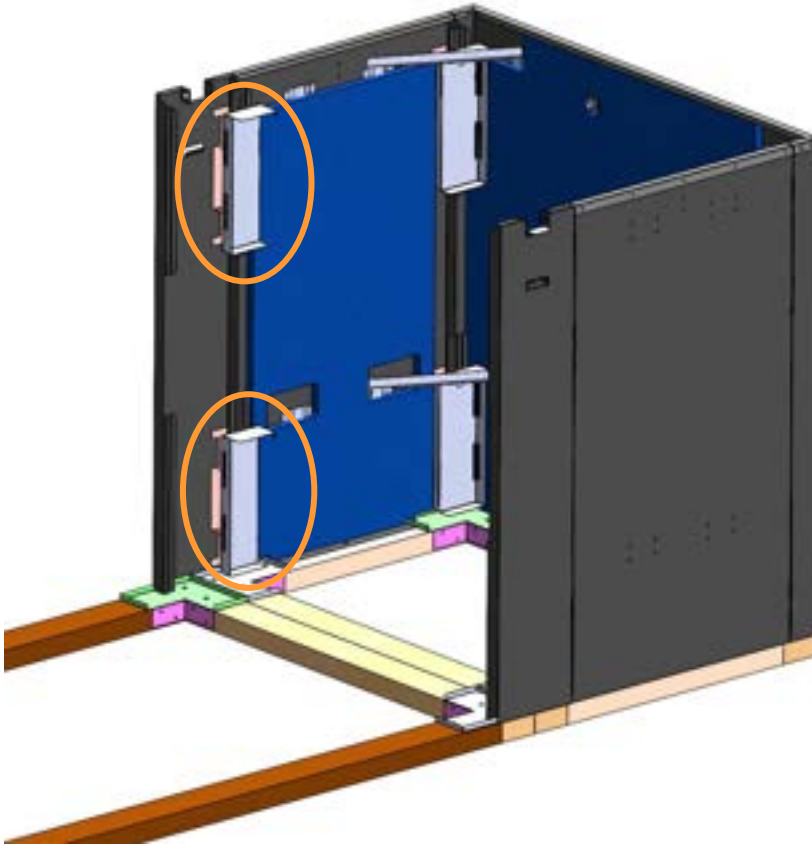

11. Slide in the other Rear Panel and attach the locking pillars labelled **“REAR LEFT”**.

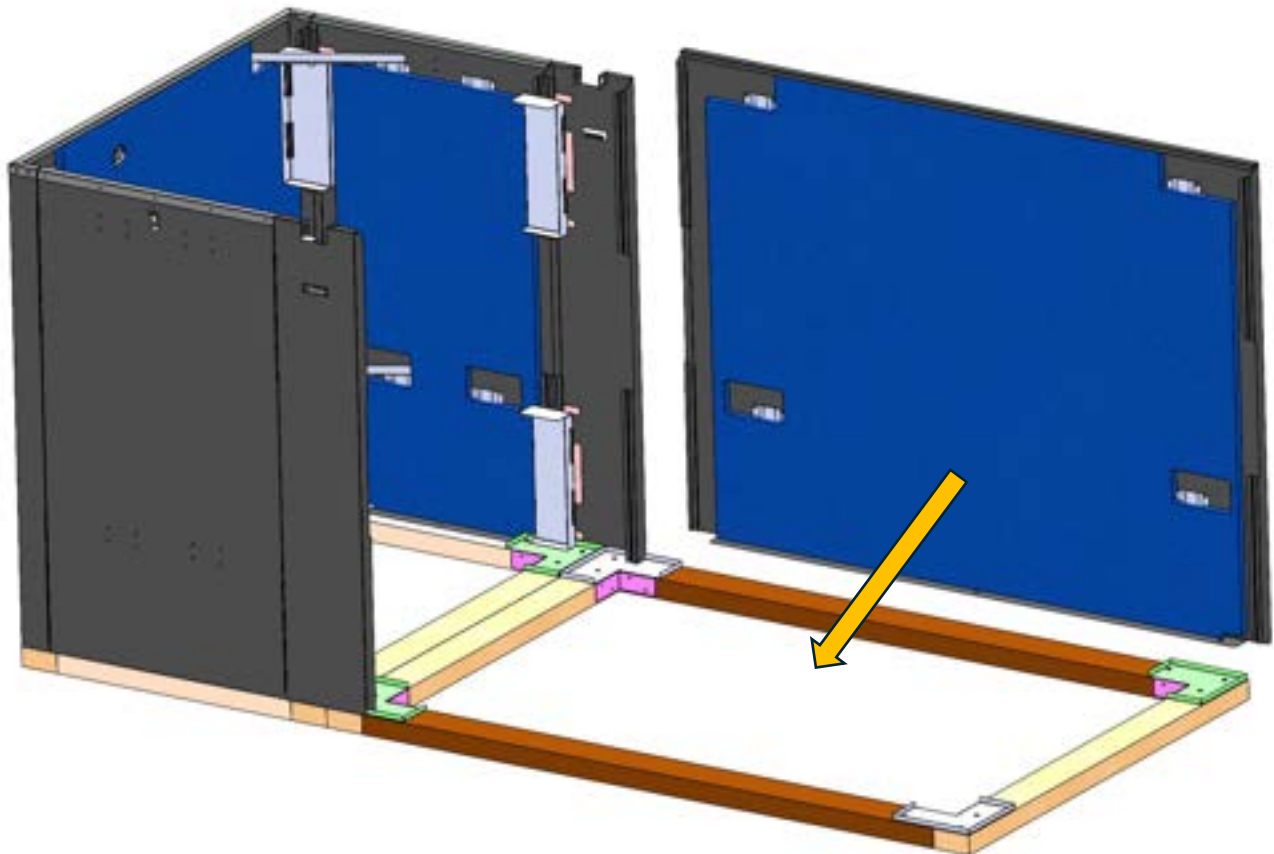

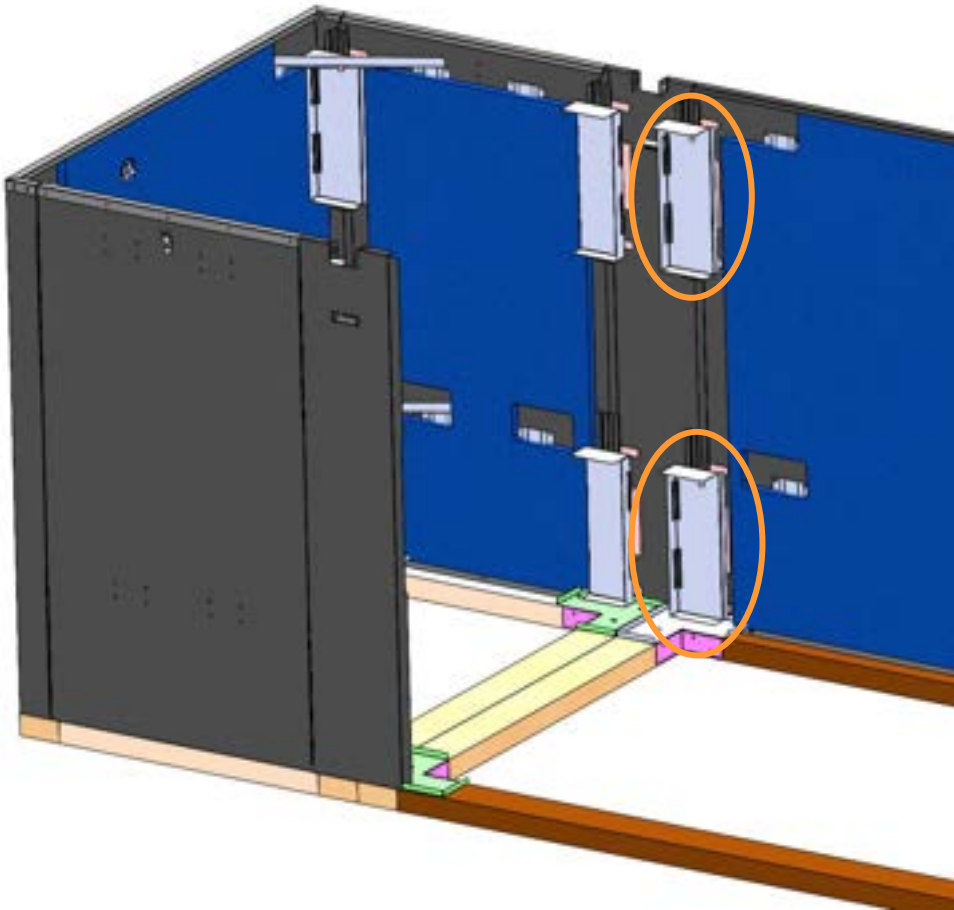

12. Slide the Right Panel and attach the locking pillars and brace labelled **“REAR RIGHT”**

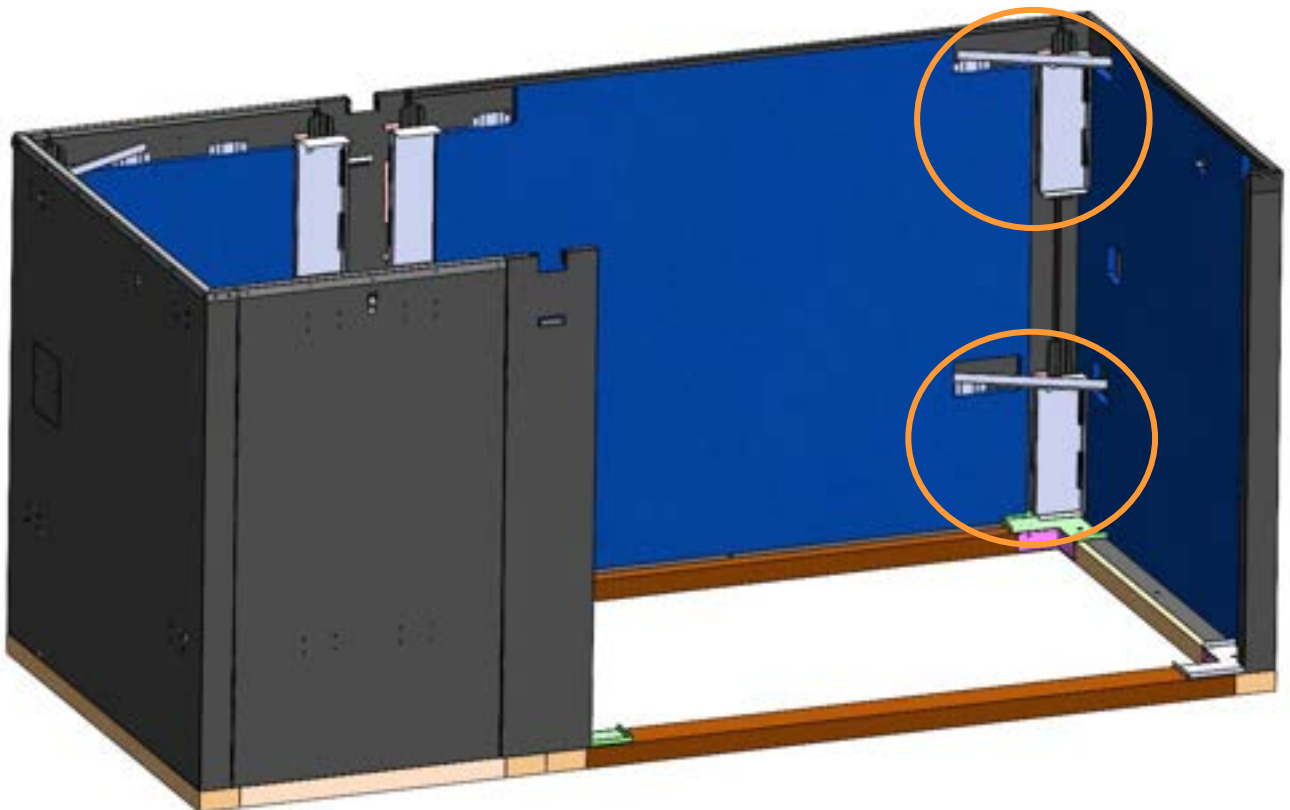

13. Repeat the same for the Front Panel

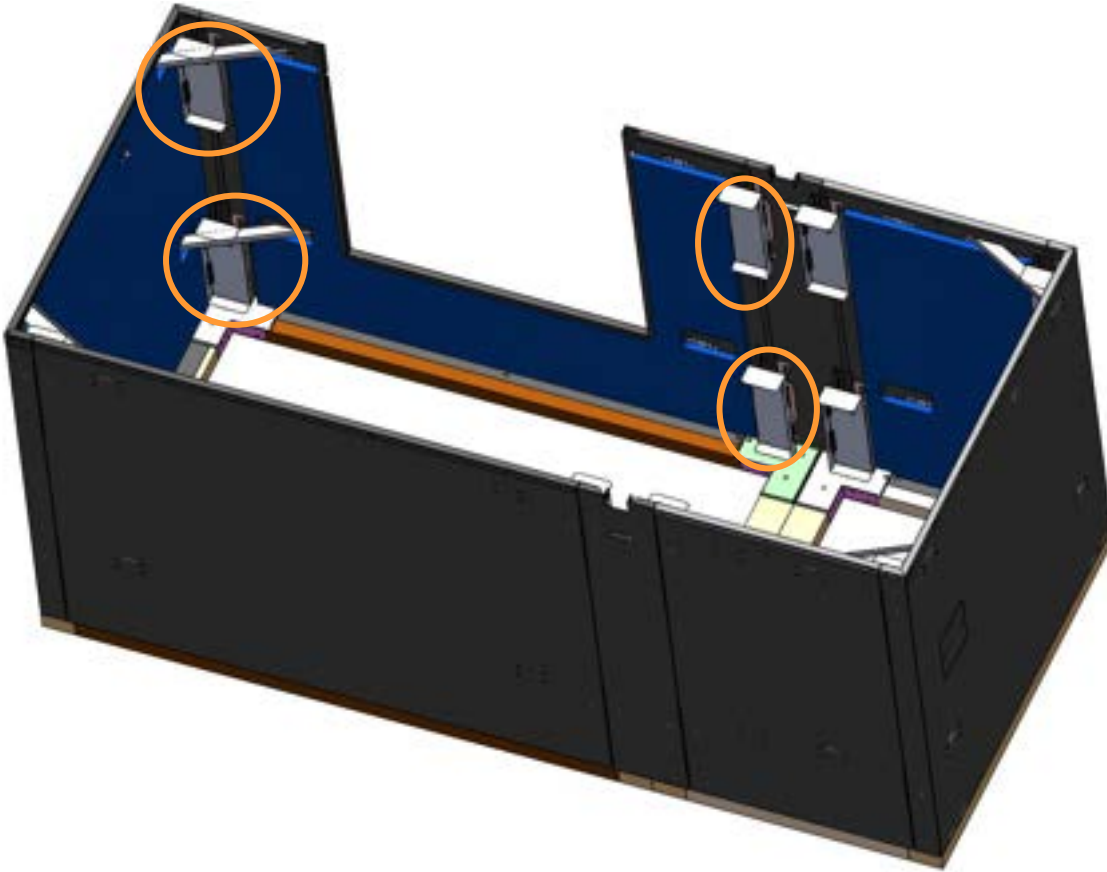

14. Insert the joining assembly by sliding down vertically into the tabs on the joiner
(Refer to the label on the joining assembly to align in the correct direction)

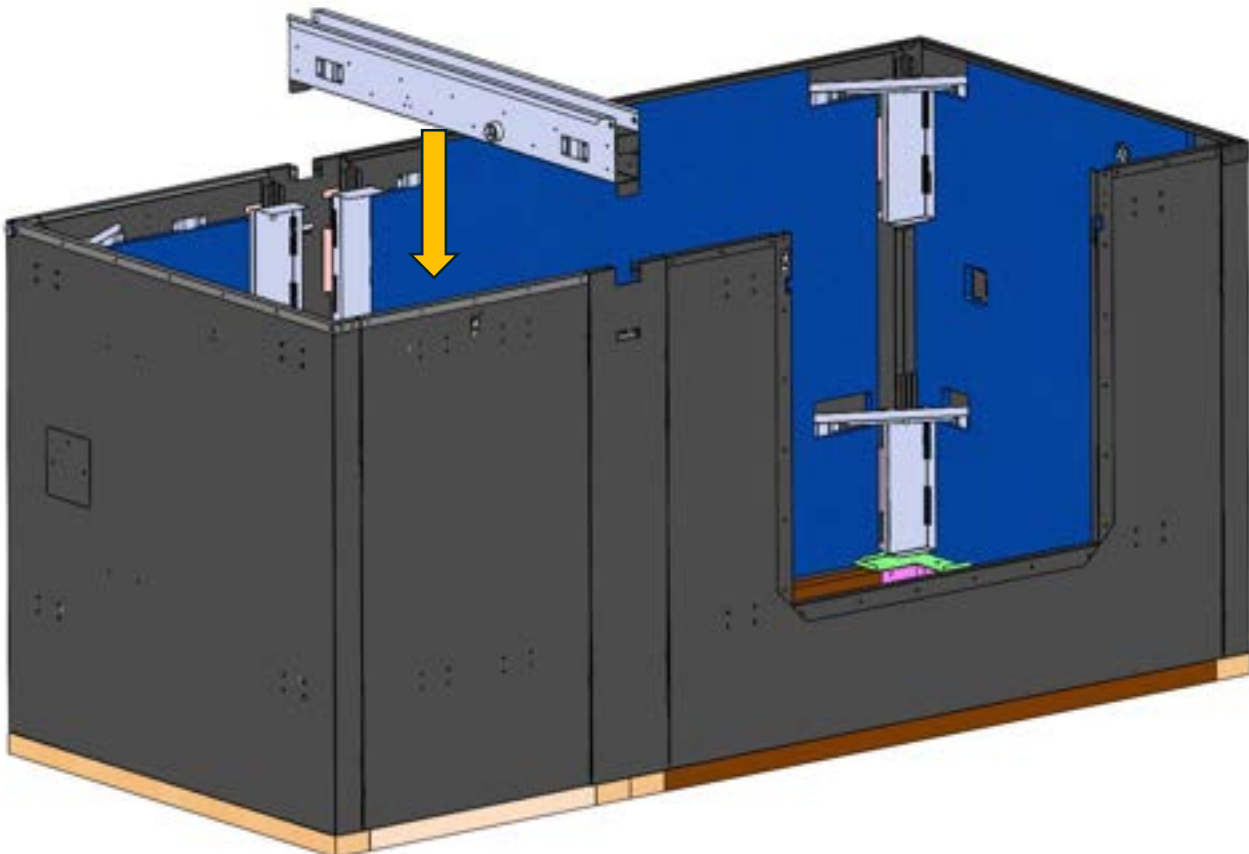

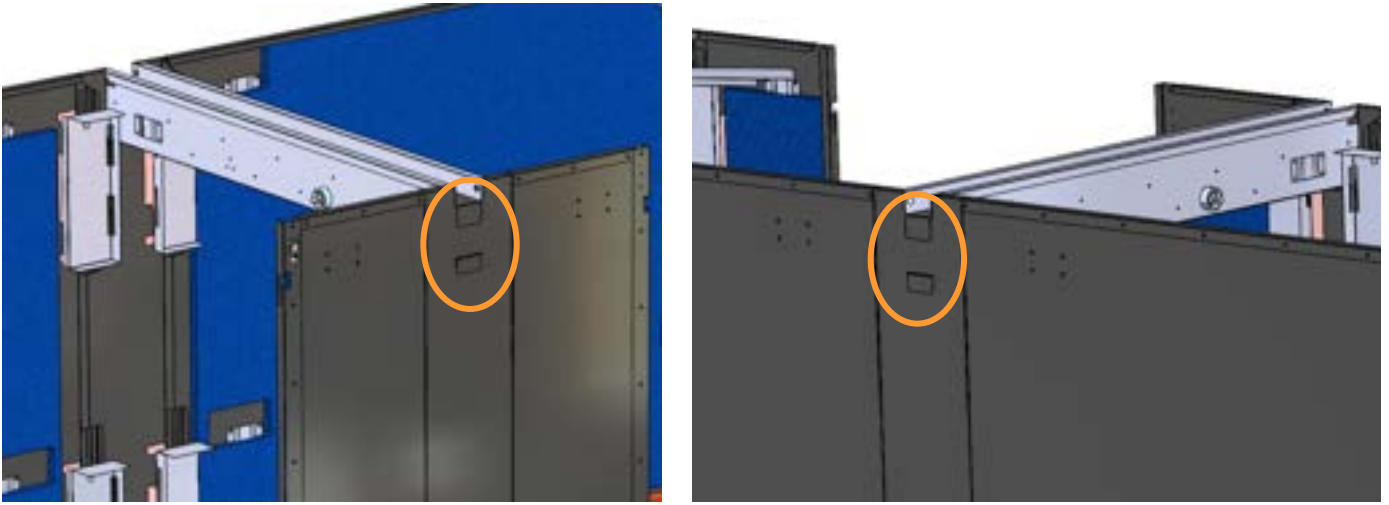

15. Insert the rear and front brace for each side

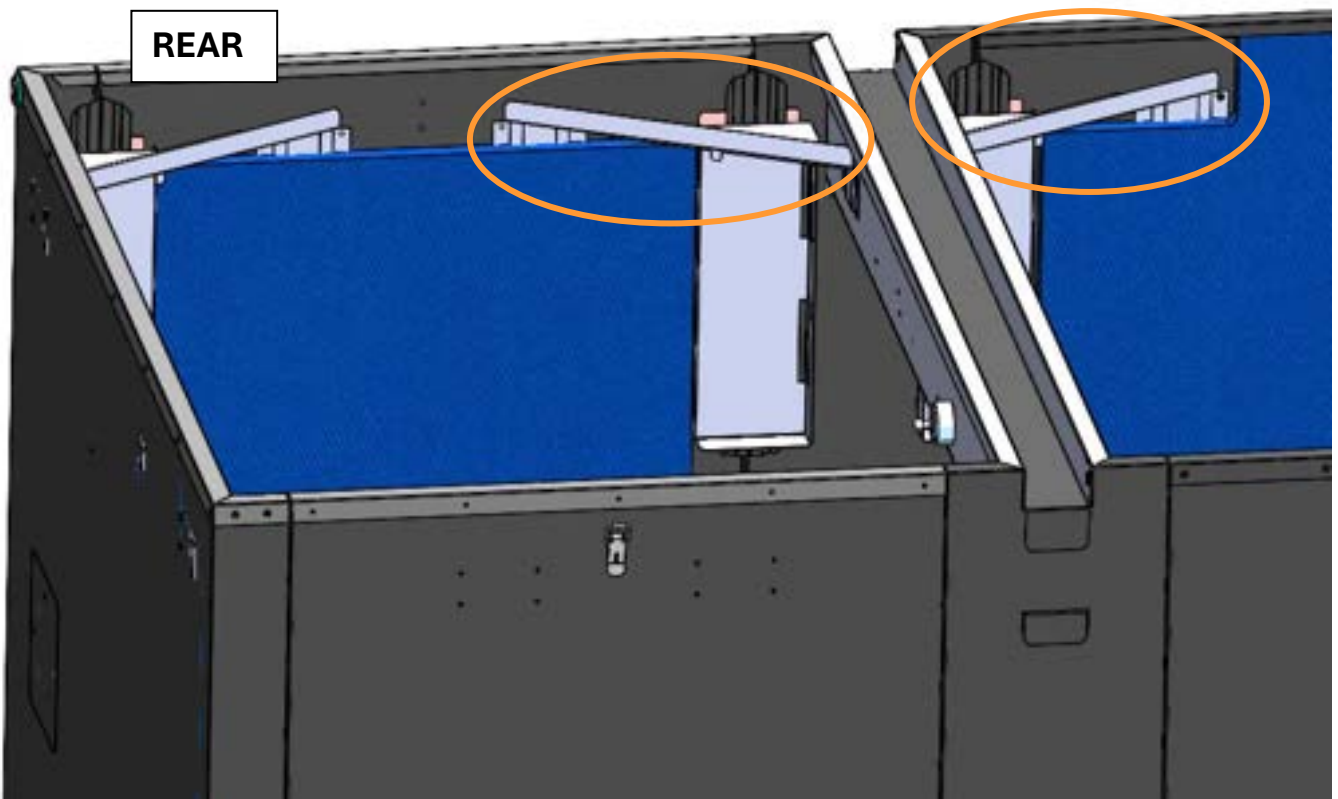

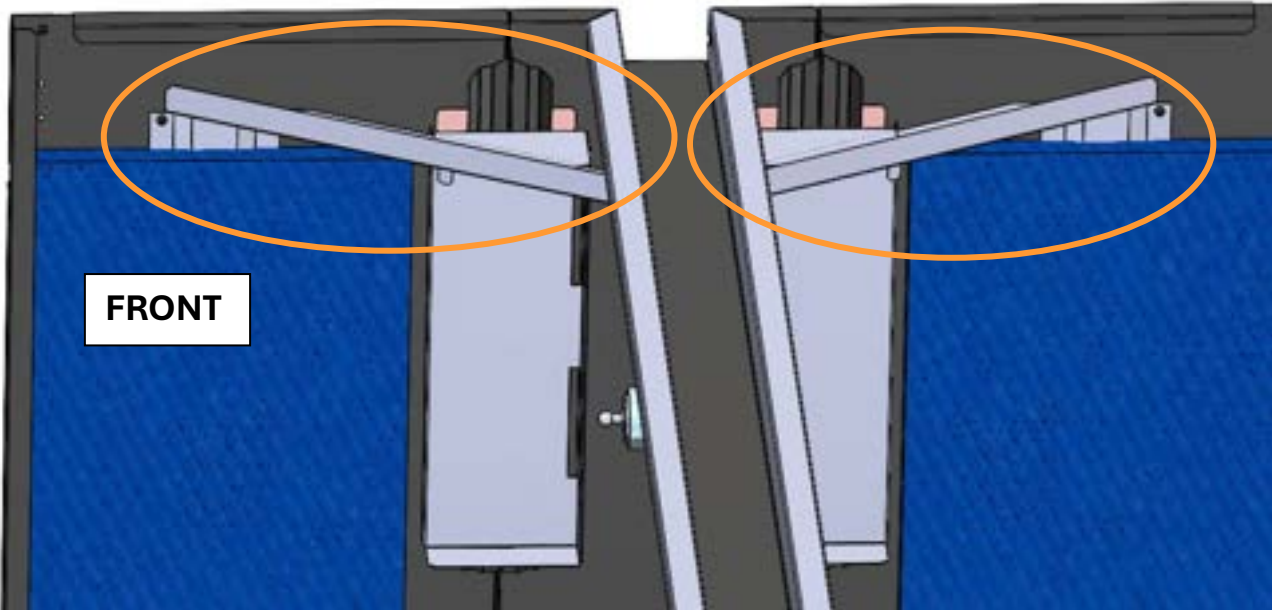

16. Attach the white washer and the black bush provided to the **REAR joiner** as shown in image

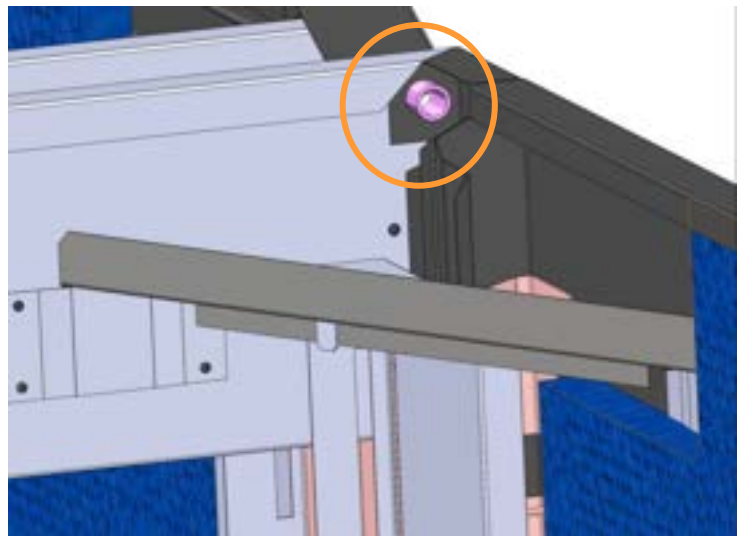
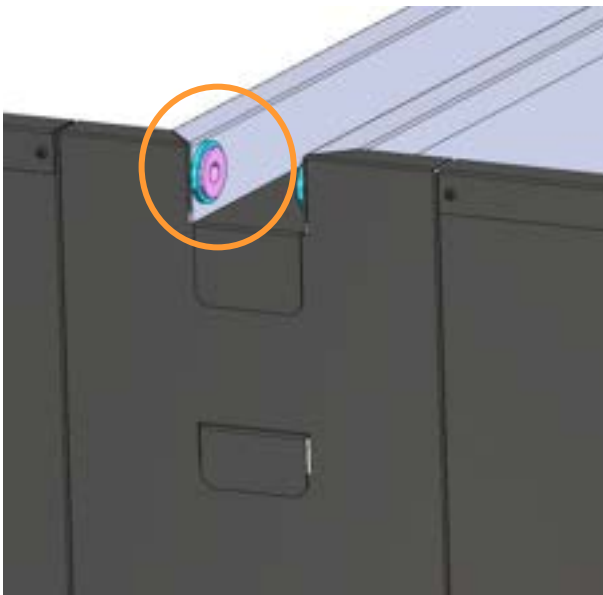

17. Repeat for the other end of the Rear joiner



18. Insert the White Washer into the Black Bush and push the assembly into the hole of Side Panel. Repeat the same for the other side.



19. Rest the Small lid on top of the enclosure and push in the Hinge Pin from both sides of the lid

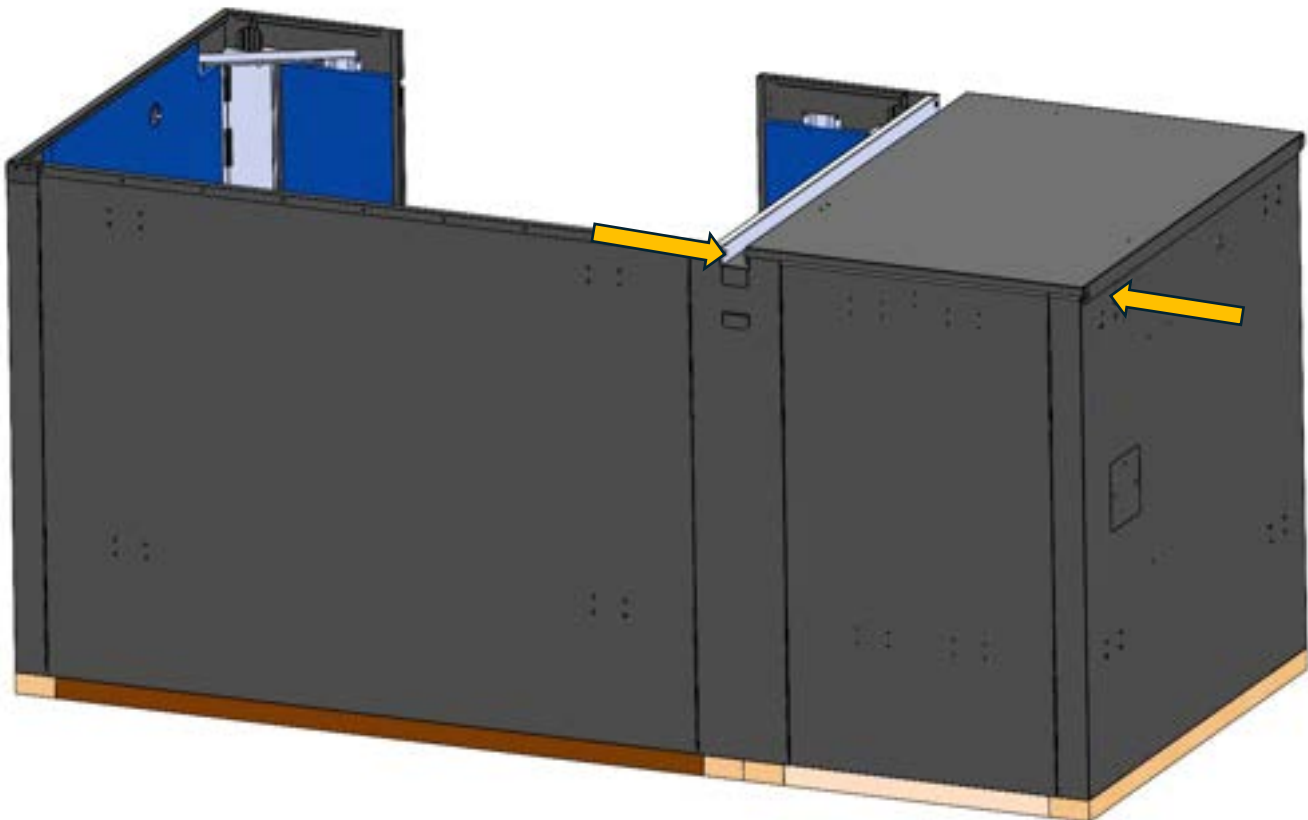

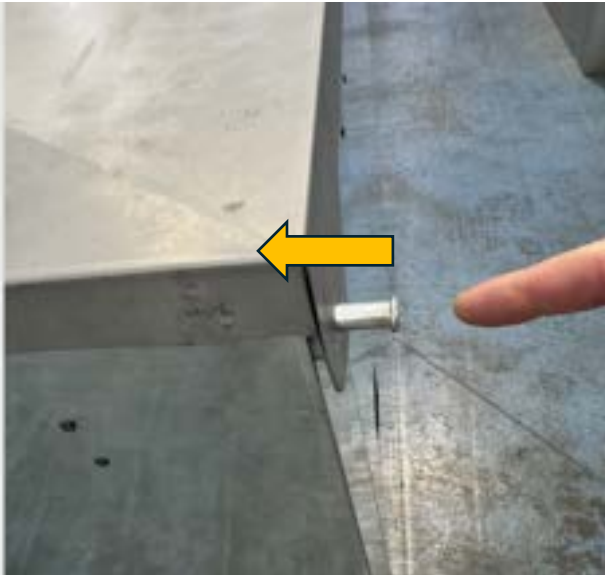

20. Lift up the lid and fit the retaining clip into the Hinge Pin using a long nose plier

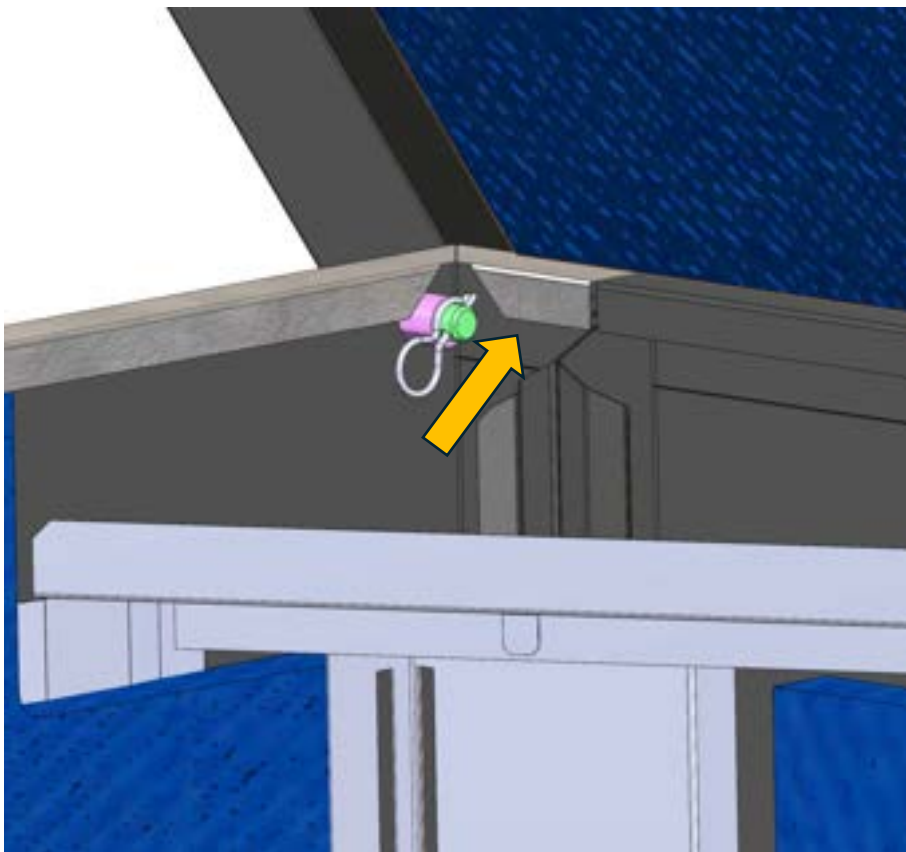

21. Repeat the same for the other side

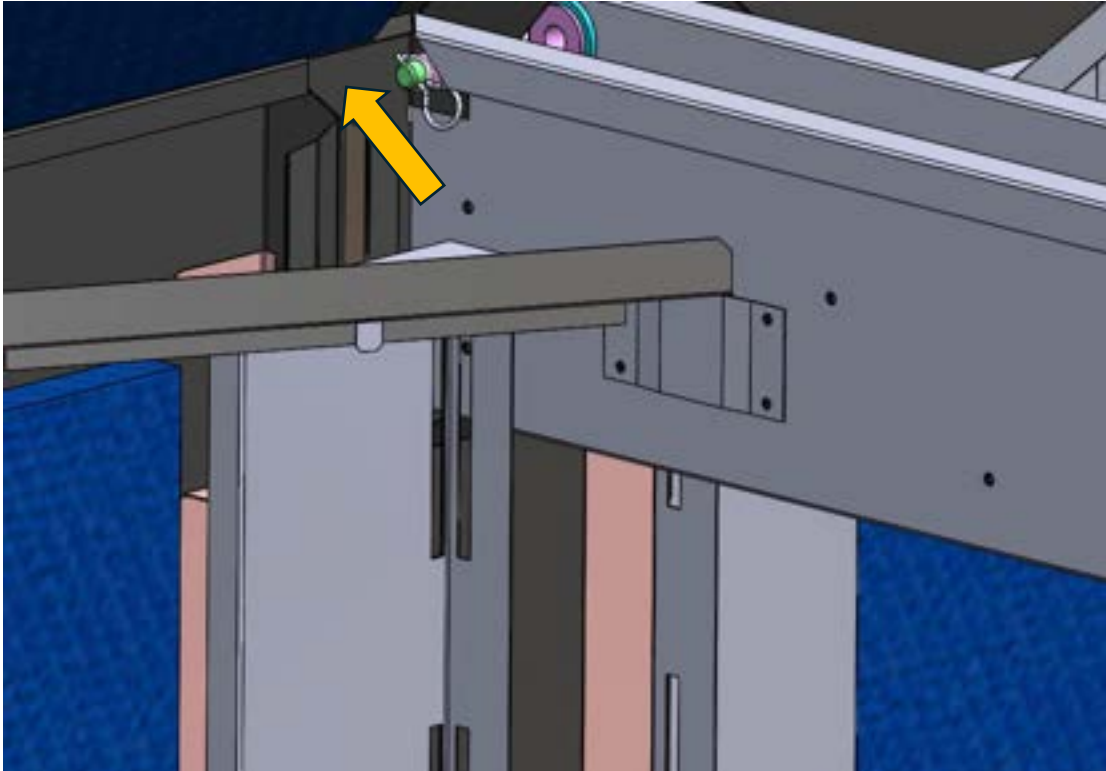

22. Fit the Gas struts labelled “50N” into the SMALL Lid.

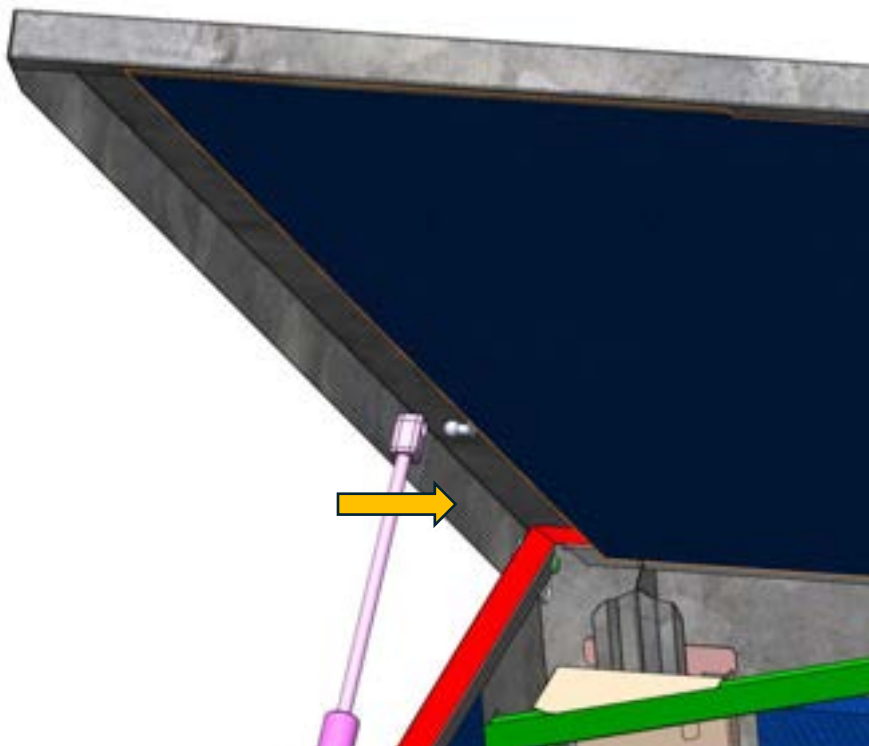

23. Attach the Gas Struts onto the Strut mounting pin on the side panels

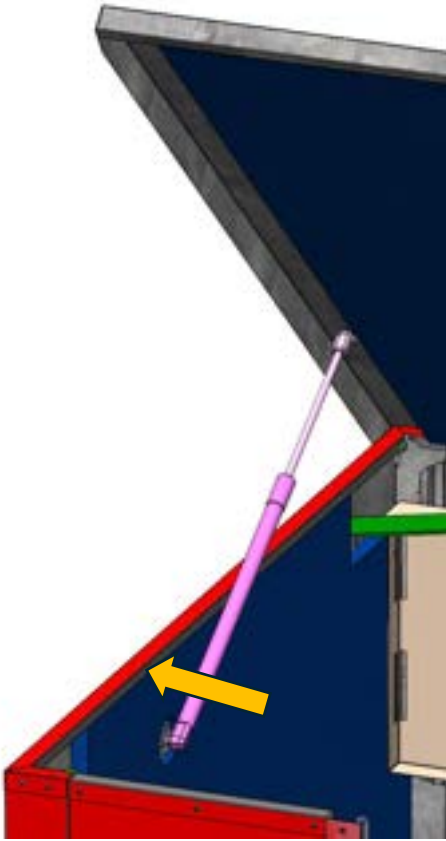

24. Repeat the steps 18-22 to assemble the other Lid using the other set of Gas Struts

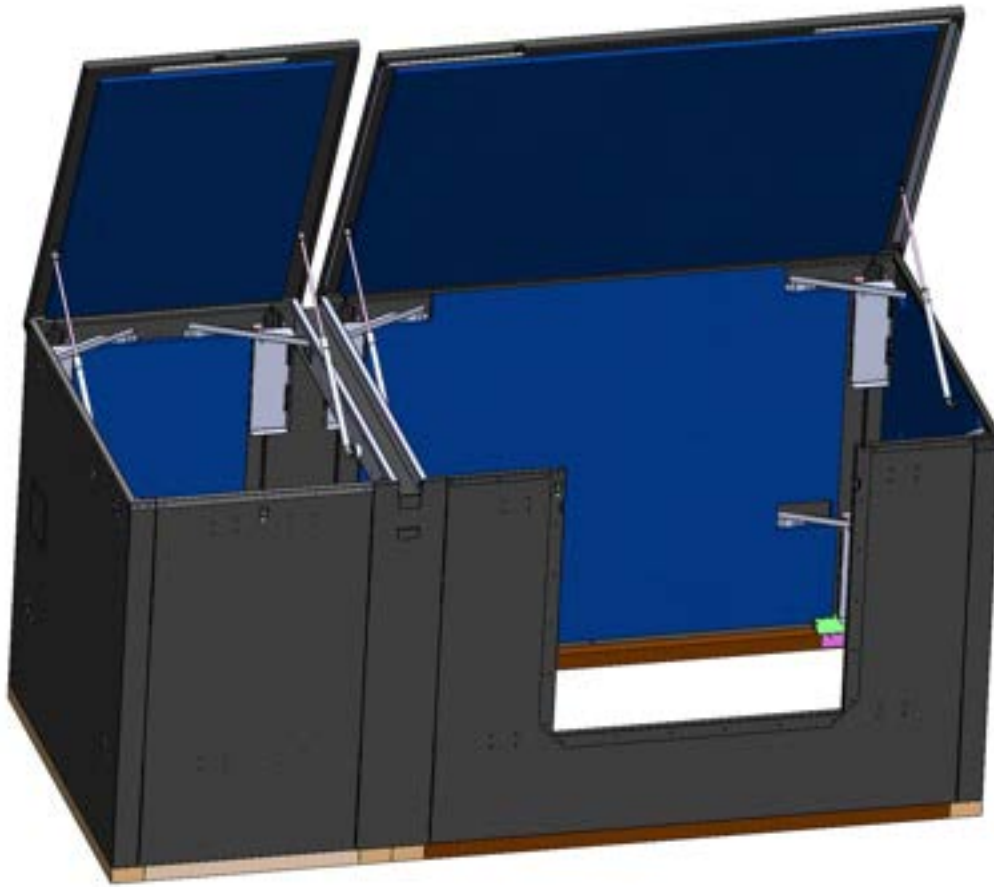

25. Attach the Back panels by pushing the tabs into the cutouts on the locking pillar and sliding it down.

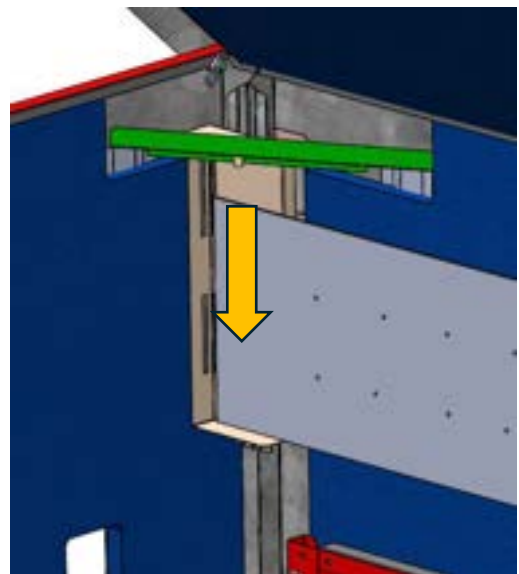
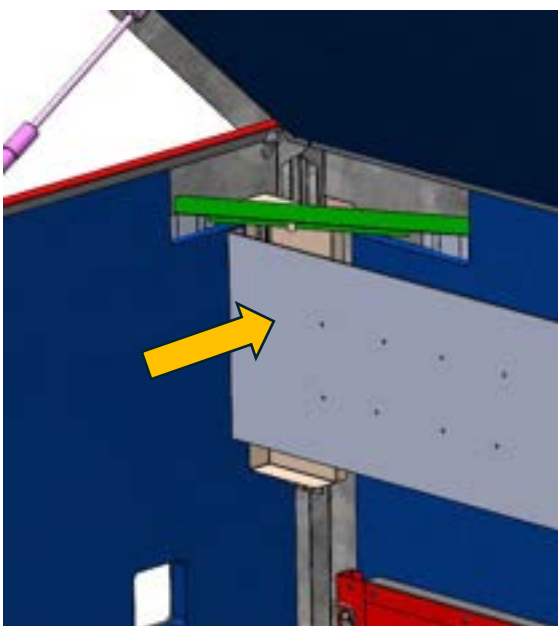

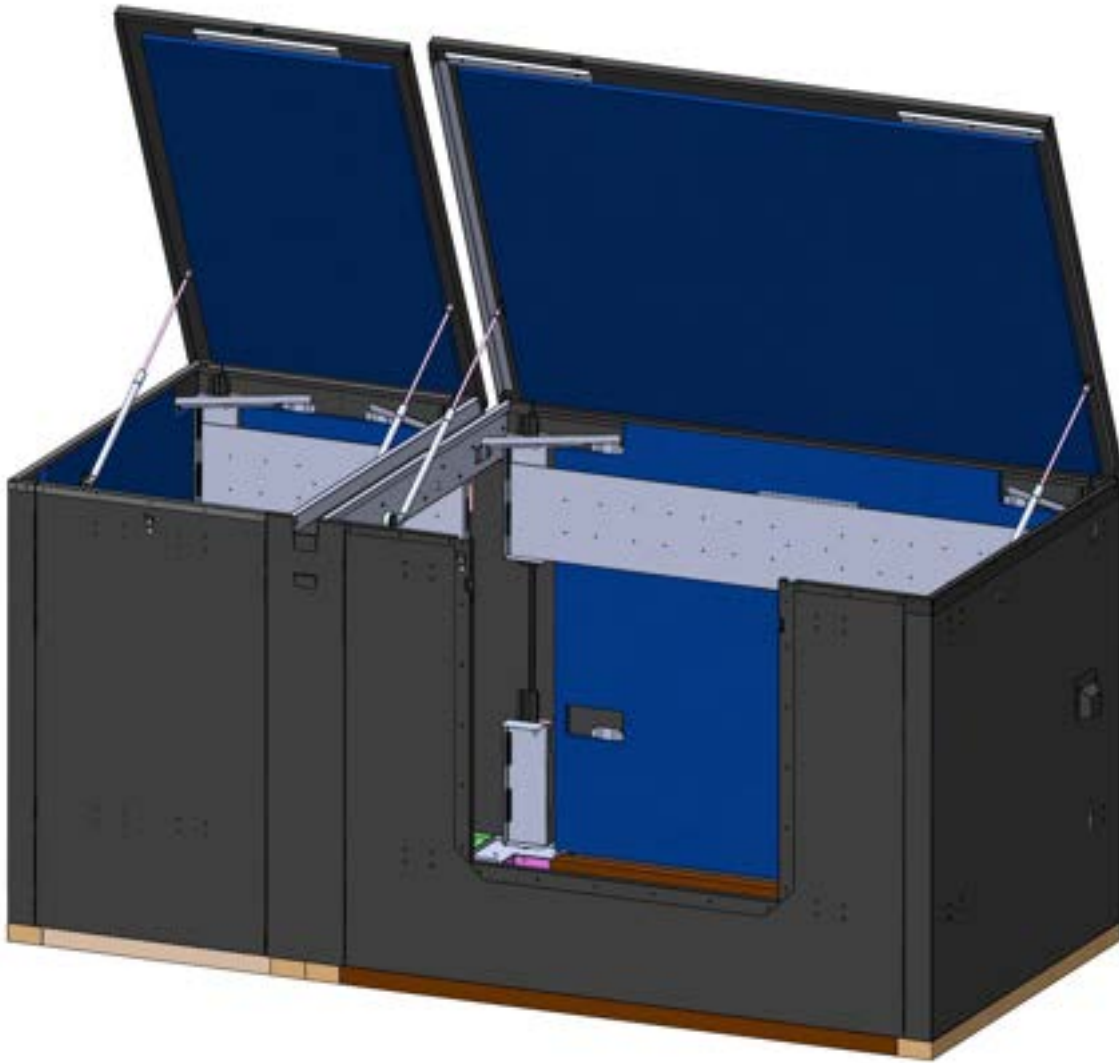

26. Repeat the step 14 to attach the side panel

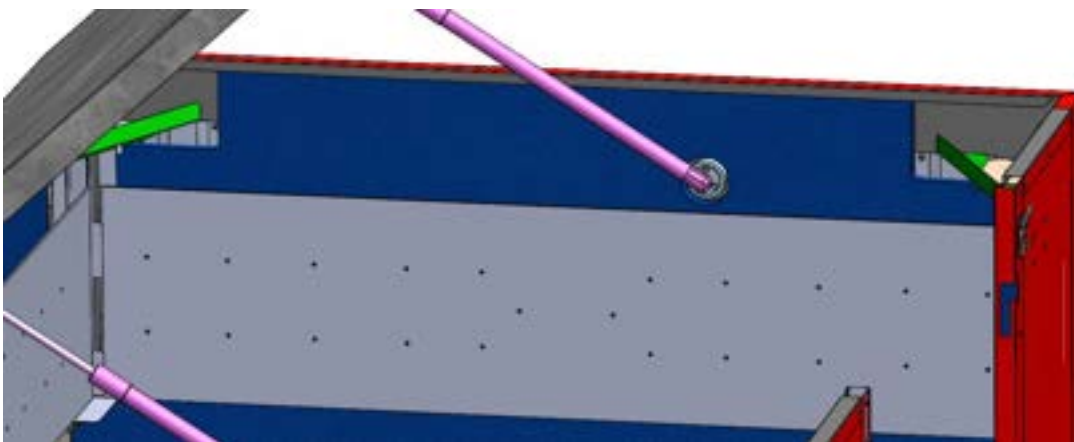

27. Slide in the door on to the front panel

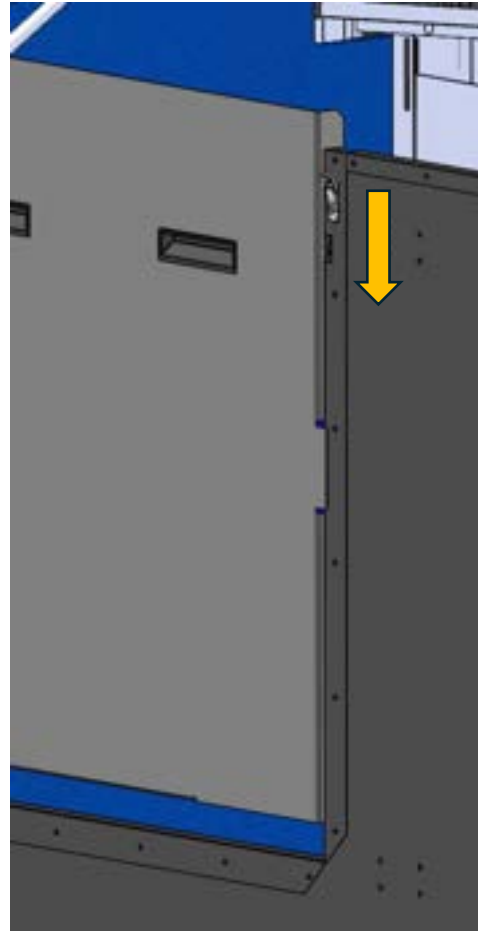
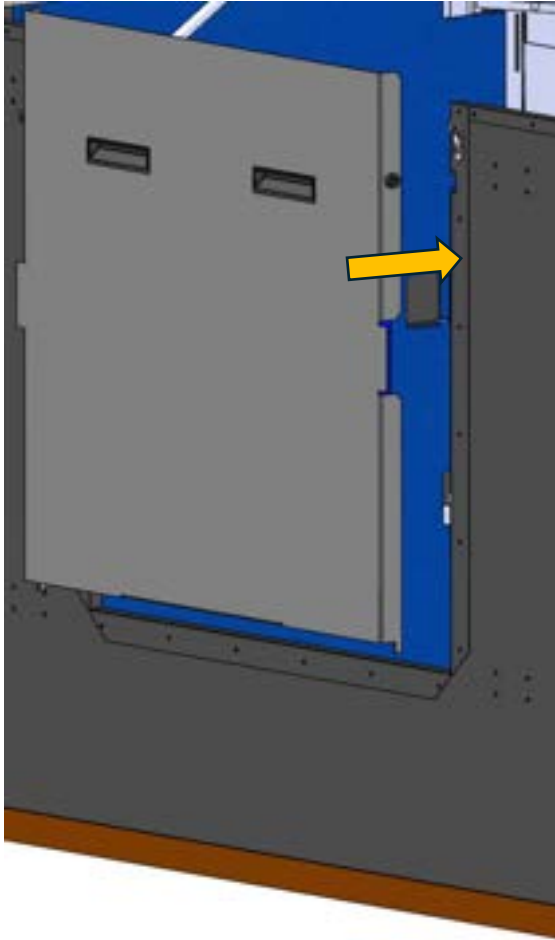

MAIL

57-59 Nantilla Road,
Clayton, VIC, 3168

LANDLINE

1800 INSNRG (1800 467674)

WEBSITE

www.insnrg.com

ONLINE PARTS

www.insnrgintouchparts.com

EMAIL

sales@insnrg.com

InTouch APP

www.insnrgapp.com