

INSTALLATION AND OPERATING MANUAL

# A GUIDE TO YOUR Ci CARTRIDGE FILTER

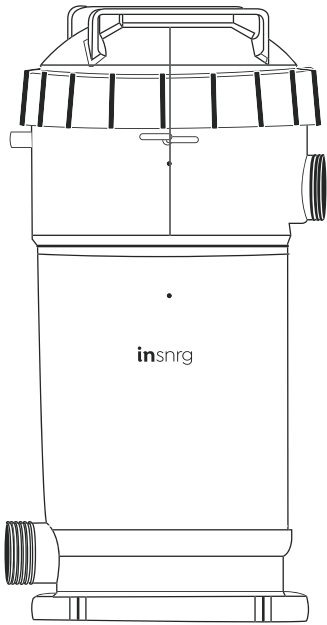

# CONGRATULATIONS ON PURCHASING YOUR INSNRG Ci CARTRIDGE FILTER.

THIS MANUAL HAS BEEN CAREFULLY DEVELOPED TO GIVE YOU ALL THE INFORMATION YOU NEED TO GET THE BEST VALUE FROM YOUR PURCHASE.

It is important that you read through the manual to identify the key areas you need to understand, particularly the following:

- Health and Safety Concerns
- Installation requirements
- How to operate the major features of the unit
- The importance of maintenance
- If you have a problem, what to trouble shoot before you contact your professional
- Finally, your entitlements under your product warranty.

Insnrg have developed their product to provide you with the ultimate experience and are sure you will be delighted with your purchase.

Please note: This equipment must be installed in a location that allows for regular maintenance and service by the pool owner and service technicians. Insnrg will not put service technicians at risk of injury by servicing difficult to access appliances.

# THE IMPORTANT BITS

**04** SECTION 1:  
We care about your safety

**06** SECTION 2:  
We want you to be delighted  
Specifications and Dimensions  
Installation

**14** SECTION 3:  
Now to Have some Fun  
Cleaning  
Winterising

**18** SECTION 4:  
Oops, something not right?  
Maintenance  
Troubleshooting  
Replacement Parts  
Warranty

## SECTION 1

# WE CARE ABOUT YOUR SAFETY



## IMPORTANT WARNINGS

Warning – read and follow all instructions in this owners manual and on the equipment. Failure to follow instructions can cause severe injury and/or death.

Insnrng highly recommend the installation of all their equipment by a suitably qualified pool professional who will ensure your high performance Insnrng products are installed to your local standards and codes to ensure optimum safety and performance.

## CAUTION

All components of the filtration system including Pumps, Filters, Heaters must be positioned so to prevent being used as means of access to the pool by young children. To reduce risk of injury, do not permit children to use or climb on this product. Closely supervise children at all times.



### WARNING- HAZARDOUS PRESSURE.

Pool and Spa water circulation systems operate under hazardous pressure during start up, normal operation, and after pump shut off. Stand clear of circulation system equipment during pump start-up. Failure to follow safety and operation instructions could result in violent separation of the pump housing and cover, and/or filter housing and clamp due to pressure in the system, which could cause property damage, severe personal injury, or death. Before servicing pool and spa water circulation systems, all system and pump controls must be in the off position and filter manual relief valve must be in open position. Before starting system pump, all system valves must be set in a position that allows system water to return back to the pool. Do not change filter control valve position whilst system pump is operating. Before starting system pump, fully open filter manual air relief valve. Do not close filter manual air relief valve until a steady stream of water (not air) is discharged.



### WARNING- RISK OF ELECTRICAL SHOCK OR ELECTROCUTION.

Ensure that you position the filter to allow for the air/water bleed valve located in the lid to safely direct water drainage and purged air or water. Water discharged from an improperly position filter can create an electrical hazard that can cause severe personal injury as well as damage property.

## SECTION 2

WE WANT YOU TO BE  
DELIGHTED WITH YOUR  
PURCHASE, CORRECT  
INSTALLATION WILL PROLONG  
LIFE AND MAXIMISE THE  
PERFORMANCE OF THIS UNIT.

Congratulations on your  
purchase of an Insnrg  
Ci Cartridge Filter.

Your filter is high performance  
and corrosion proof  
designed with superior flow  
characteristics that is easy to  
operate. Everything is made  
simple from installation,  
operation, to the maintenance  
of the filter. Your Insnrg filter  
will provide crystal clear,  
healthy swimming water with  
minimal maintenance.

Insnrg highly  
recommend the  
use of qualified  
service technicians  
to ensure the best  
performance as  
well as the health  
and safety of your  
family.

## HOW IT WORKS

Your Insnrg cartridge filter is designed to use the high quality filter elements to remove dirt particles from pool water. These elements are specifically designed for your Insnrg cartridge filter and if looked after will provide you with years of trouble free operation. The pool water which contains dirt particles is pumped through your system to the filter. As pool water passes through the filter, dirt particles will be caught by the filter element and removed from the water. The cleaned pool water is returned back to the pool through your piping system. The entire process is continuous and automatic. It is this process that provides the filtration and removal of organic material such as dust, dirt and fine particles in your pool water.

During this process, dirt will accumulate in the filter element and gradually increase the pressure in the tank and reduce the flow of water through your filtration system. This means it is time to clean your filter element. A good indication when to clean the filter element is by checking the pressure gauge reading. Cleaning should be performed when you notice the pressure has increased by 20 kPa from when it was clean. Following the cleaning procedure for the best results.

# SPECIFICATIONS AND DIMENSIONS

The Insnrg range of Cartridge Filters comes with a model ideally suited to your pool depending on the size of pool, other equipment and the bather load. Your local pool professional will ensure that you have sized correctly for your application. The below chart outlines key dimensions for each model to assist you with your installation.

Model #	Ci 100	Ci 150	Ci 200	Ci 250
Filtration Area (m2)	9.3	13.9	18.6	23.2
Filtration Area (ft2)	100	150	200	250
Max Flow Rate (litres pm)	380	500	500	500
Max Flow Rate (gallons pm)	100	130	130	130
Turnover Capacity – 8 Hours (Litres)	182,400	240,000	240,000	240,000
Turnover Capacity – 8 Hours (Gallons)	48,000	62,400	62,400	62,400



### Ci 200 and Ci 250

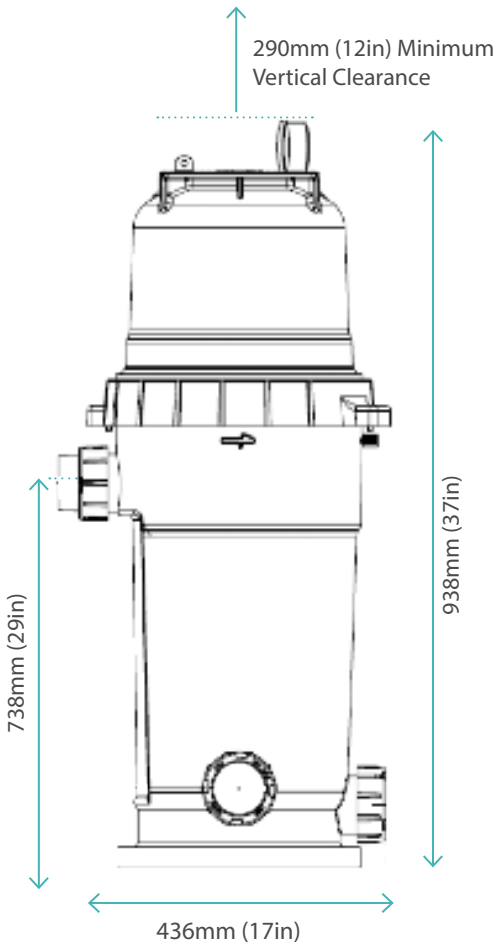

### Ci 100 and Ci 150

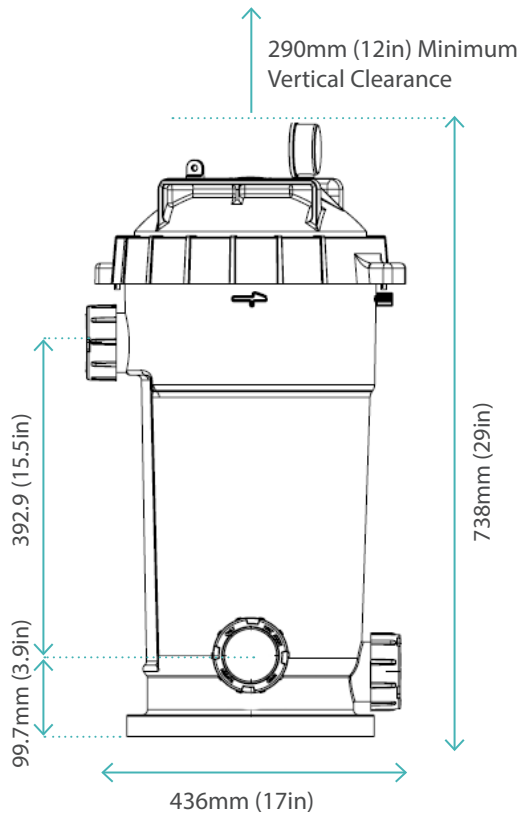

# INSTALLATION

The Cartridge Filter should be installed as close to the pool as possible but keep a distance of at least 3.6 metres. Locate the Cartridge Filter on rigid, level surface, preferably in a dry, shaded, and well-ventilated area. Prior to installation take into consideration the following conditions:

- Position of suction and return PVC connections
- Access for cleaning operation and servicing, particularly important if installing under a deck or roof structure that enough space is provided to remove the element for cleaning
- The operation of the Air-Bleed will discharge water from the filter, you must position the filter so none of this water can come in contact with electrical devices and cause electric shock or electrocution.
- Protection from sun, rain, splashing etc
- Drainage of filter room
- Ventilation and protection of the full filtration system

Once you are happy that the above has been considered, follow these steps:

- 1) Place the empty tank in position
- 2) Line up the PVC pipe from the Pump with the Inlet on the Cartridge Filter and use Lock Nut and Tail to install. The inlet has been designed so you are able to come directly from the Pump and minimise bends to reduce pressure and improve water flow.
- 3) There are two outlets at the base of the filter. One, identified as "outlet" must be plumbed to the return pipe to the pool and spa. The other is only a drain valve to enable you to drain the filter of water.

- 4) Connect the Outlet to the PVC pipe with Lock Nut and Tail.
- 5) Replace Element into Tank
- 6) Replace Lid onto Tank and tighten. Do not overtighten as this could cause tank to warp and product to leak.
- 7) Gently install Pressure Gauge into Lid after wrapping the pressure gauge thread with teflon tape. Do Not Overtighten or you may crack the lid of the cartridge filter.
- 8) Install Air-Bleed into Lid. Do not tighten and allow air to escape once water starts flowing through the filter.

**WARNING – RISK OF ELECTRICAL SHOCK OR ELECTROCUTION.**

Ensure that you position the filter to allow for the air/water bleed valve located in the lid to safely direct water drainage and purged air or water. Water discharged from an improperly position filter can create an electrical hazard that can cause severe personal injury as well as damage property.

**9)** Check that all other fittings in the filtration system are correct and ready for operation. Make sure any Valves that you closed are re-opened ready for filtration.

**10)** Turn on Pump. Prior to starting the filtration process by turning on the pump, we highly recommend that you read through the pump instruction manual to ensure proper installation and to avoid the risk of electric shock.

**11)** Water will start to move through Filter and release Air through the Air-Bleed. Once a full stream of water comes through the Air-Bleed gently tighten to seal.

**12)** Check for any other leaks and tighten as necessary

**CONGRATULATIONS, YOU HAVE NOW  
INSTALLED YOUR NEW INSNRG FILTER.**

## OTHER IMPORTANT INSTALLATION TIPS

1. Never subject the filter to pressure in excess of the maximum working pressure, even when conducting hydrostatic pressure testing. Pressures above the maximum working kPa pressures can cause the lid to be blown off and result in severe injury, death or property damage. Maximum working pressure is 250 kPa.
2. The filter should be mounted on a level concrete slab. Position the filter so that the instructions, warning and pressure gauge are visible to the operator. It should also be positioned so that the piping connections, control valve and drain port are convenient and accessible for servicing and winterizing.
3. Install electrical controls (timers, Chlorinators, power points) at least 1.8 from the filter. This will allow you enough room to stand clear of the filter during start up.
4. All filter connections are provided with an gasket / o-ring seal. To avoid damage to the gasket / o-rings, use only a silicone base lubricant. Do not use any other substances as it will degrade the gasket / o-ring and reduce its performance and lifespan.
5. Install the pressure gauge (supplied with the filter) into the marked hole in the lid, using Teflon tape wrapped around the pressure gauge thread. **DO NOT OVERTIGHTEN.**

6. If the filter is installed below water level, isolation valves must be installed on the inlet & outlet to enable the filter to be dismantled for cleaning without the loss of water from the pool or spa.

7. It is recommended that a 3 way valve be installed on the return line to allow draining of water from the pool or spa when necessary.

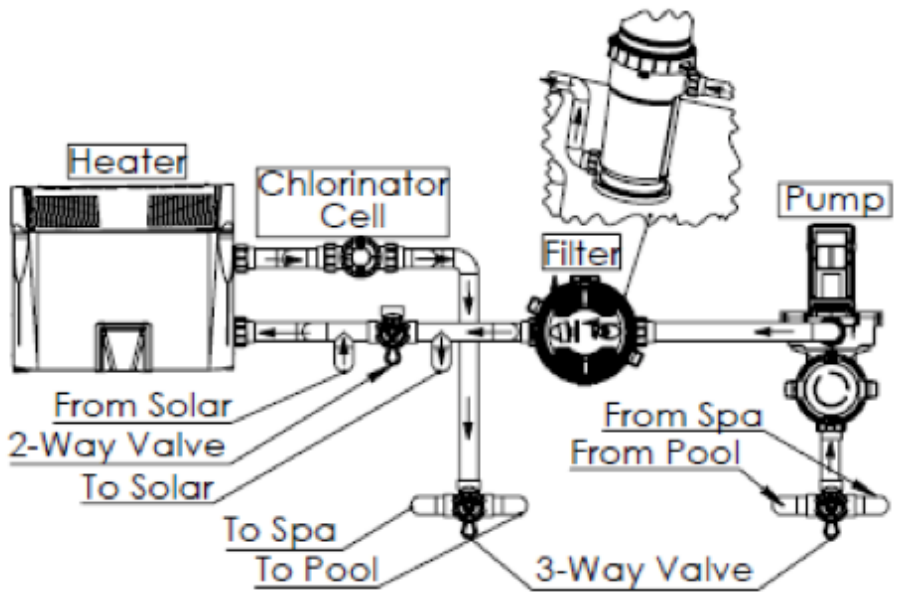

## SECTION 3

# HAVE FUN AND GET THE MOST OUT OF YOUR PURCHASE

Now that your Insnrg Cartridge Filter is installed and operating, it is important to understand how to keep it in the best condition and give you the best results for many years to come.

# CLEANING YOUR FILTER ELEMENTS



## WARNING

Cleaning your cartridge filter is essential to providing clean, safe and healthy swimming water. While landscaping works are undertaken around your pool it is recommended to clean the filter cartridge every 2 or 3 days to remove tile, cement and timber dust and prevent permanent blockage to the polyester element.

The Cartridge Filter Elements require cleaning when the water flow through the filtration system reduces or reading on the pressure gauge increases by 20 kPa from the original operating pressure when the filter element was clean.

TO CLEAN YOUR FILTER ELEMENTS, FOLLOW THESE STEPS:

1. Stop the pump and close any valves on the suction and return lines to prevent water being lost, particularly if your filtration system is below the pool water line.
2. Open the air bleed valve (located in the filter lid). Allow all pressure to be relieved.
3. Loosen the Lock Ring around the Lid and remove from the filter.
4. Carefully remove the filter element from the filter. It is important that you treat the element carefully to ensure effective cleaning and a long life span. Any damage done during cleaning is not covered by the product warranty.

5. Clean the elements by using a garden hose to remove any debris, dust, organic material from the element pleats. It is important to get into the pleats as most debris is positioned well inside the element. An alternate way to clean the element is to soak in a mild solution of cartridge element cleaner which can be purchased from your local pool professional and then hose off with water.
6. Replace the clean element into the filter ensuring it is correctly located on the bottom spigot of the filter.
7. Clean the filter lid o-ring before refitting, ensure it is free from dirt.
8. Place the lid carefully over the elements and lower onto the lower body of the filter. Ensure o-ring stays in place.
9. Screw down the Locking Ring until the buttons on each side click 2 or 3 times. DO NOT over tighten as this could cause the tank body to warp and create potential for permanent leaking.
10. If needed, open the valves on suction and return lines, then ensure the air bleed valve in lid is still open
11. Turn the Pump on
12. Wait for constant stream of water from the air bleed valve, then close valve.
13. Check for leaks from around clamp band

**CONGRATULATIONS YOU HAVE CLEANED  
YOUR CARTRIDGE FILTER.**



# WINTERISING

Is it important to protect your High Performance Insurg Cartridge Filter from freezing water conditions. As water freezes it expands and that can cause the internals of the Cartridge Filter to break under the intense pressure of expanding water. It is your responsibility to monitor temperatures and take the following actions:

In mild climate areas, when temporary freezing conditions may occur, run your pump and filtering equipment all night to maintain water circulation and prevent freezing.

If freezing conditions are expected, take the following steps to reduce the risk of freeze damage. Freeze damage is not covered under warranty.

1. Clean your Filter Element thoroughly before closing down the pool for winterising. This will ensure no debris remains in the element during the long winter break and the filtration system is ready to go when the swimming season returns. Ideally, remove the element from the Filter and store safely indoors.
2. Drain the filter tank by removing the Blanking Cap on the non-used Outlet. Leave the cap off and store safely indoors.
3. Unscrew the pressure gauge from the Filter Lid and store safely with the Blanking Cap.
4. Drain and winterise pump according to pump instructions.
5. This is an ideal time for any repairs that may be required during the off-season. Most pool professionals will recommend what is needed before the next pool season, so contact them for a thorough maintenance plan.

## SECTION 4

# OOPS, SOMETHING'S NOT RIGHT?

Maintenance, Trouble Shooting,  
Replacement Parts, Warranty &  
Contact Section

# MAINTENANCE

Your Ci Cartridge Filter has been designed to withstand harsh outdoor conditions and withstand high velocity water with chemicals. Some of these parts will wear in the normal course of use and require regular checks and maintenance. A well thought out pro-active maintenance schedule will identify faults early and extend the lifespan of your Cartridge Filter.

A good tip for all outdoor Filtration Equipment including your Cartridge Filter is to ensure that the equipment area is protected from any insects and vermin with a regular treatment of Surface Spray or suitable Insecticide. Most of the electronics in Pumps, Chlorinators or Heaters are well vented to protect against extremes of temperature, however this creates a popular environment for ants and other insects who are attracted to the warmer, dry environments inside the enclosures. We recommend that, with power turned off to all equipment, you spray a surface insecticide on the surfaces surrounding the equipment to prevent ant and insect ingress. Repeat every three months or as necessary to ensure no nasty surprises.

# PRO-ACTIVE MAINTENANCE PROGRAM

Like your motor vehicle it is important to maintain a regular service program for your pool equipment to ensure the best operation and long lasting results. The below chart provides a guideline to follow to best look after your valuable equipment. Regular maintenance can identify any potential issues early and save on expensive maintenance at a later date.

WHEN?	WHAT ARE YOU LOOKING FOR?	HOW CAN YOU FIX?
Weekly	Check Pressure Gauge.	If pressure increases by 20 kPa, then clean the filter elements as per instructions.
Quarterly	Check all Gaskets & Pressure Gauge	Isolate and turn off the Pump. Remove all Gaskets and turn over. You can also apply a silicon based grease to extend the life. If dry, then contact your local pool professional to replace.
	Check around the unit for leaves/debris or signs of flooding.	Replace any debris that is restricting air circulation around the Filter. If in a flood prone location, rectify.
	Check for any Insects/Ants etc	It is a good practice to use a good quality surface spray around your equipment. Make sure all units are turned off and then spray around all units to eliminate any insect/ants etc
Annual	Check Water Flow to Pool	If water flow is low, clean element thoroughly in cartridge element cleaner or NapiSan. If flow does not improve, replace filter element.

# TROUBLESHOOTING

The chart below identifies some of the main issues you may encounter with your CI cartridge filter. This should assist with the majority of problems. Insrng highly recommends regular checks and maintenance of your swimming pool equipment by a qualified pool professional. This will extend the life of your equipment and give you the best performance.

WHAT IS THE PROBLEM?	WHAT YOU CAN DO ABOUT IT?
Water is not clear	<p>Test and adjust water chemistry levels, particularly the disinfectant level.</p> <p>Filter could be dirty, clean the elements as per instructions and restart.</p> <p>Filter elements could be damaged, replace elements from your local pool professionals.</p>
Low water flow	<p>Check and clean pump strainer baskets.</p> <p>Check for leaks on all equipment, refit gaskets and seal.</p> <p>Filter could be dirty, clean the elements as per instructions and restart.</p> <p>Check Pool water level is high enough to cover the Skimmer and allow water to be circulated.</p>
High Pressure on Start-up	<p>Pump could be incorrectly sized for the Filter. Check against sizing chart in this manual and rectify as needed.</p>
Dirt returns to Pool	<p>Check for damage to Element and replace as necessary.</p>

# REPLACEMENT PARTS OF FILTER

ITEM	TYPE	DESCRIPTION	PART NUMBER
1	Part	Single Cartridge Filter	16120401001
2	Sub-Assembly	Union Assembly 2" 50mm	15201001
3	Sub-Assembly	Drain Valve Assembly 2" 50mm	15201002
4	Part	Single Cartridge Filter O-Ring	16120602001
5	Part	Small Lid (100-150 Filters)	16120401002
5	Part	Large Lid (200-250 Filters)	16120401003
6	Sub-Assembly	Lock Ring Assembly	16220005
7	Part	Pressure Gauge	10101512001
8	Sub-Assembly	Air Bleed Valve Assembly	15201003
9	Part	Filter Element (100 Sq. Ft.)	16120001
9	Part	Filter Element (150 Sq. Ft.)	16120002
9	Part	Filter Element (200 Sq. Ft.)	16120003
9	Part	Filter Element (250 Sq. Ft)	16120004

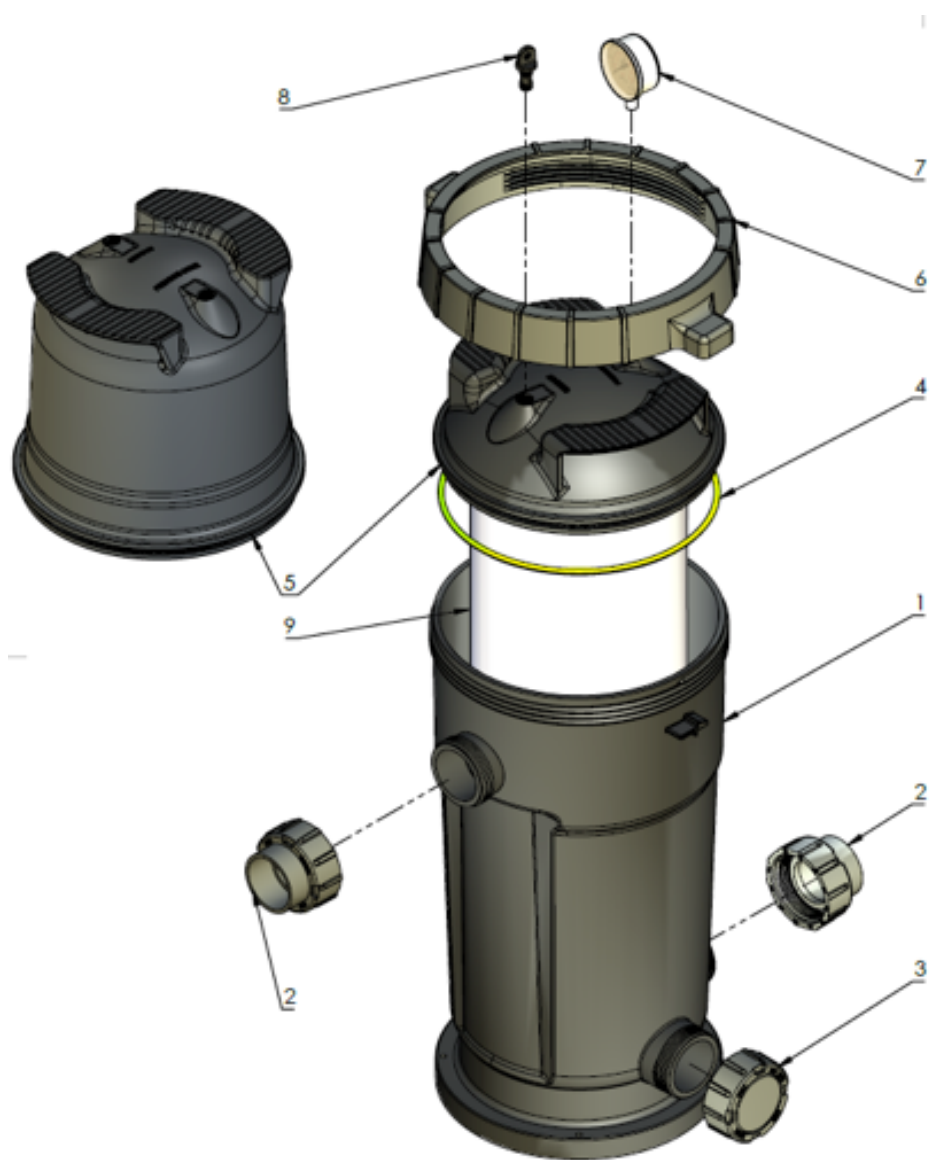

# WARRANTY

Insrg warrants that, subject to the exclusions and limitations that follow, the product will be free from defects in materials and workmanship during the warranty period. The warranty period for your Insrg Cartridge Filter is set out below and commences from the date of purchase which must be proved by the retailer invoice.

Filter Tank	3 years
Pressure Gauge	1 year
Filter Element	1 Year if properly maintained
Labour Costs	12 months only.

If a defect in materials or workmanship occurs within the warranty period Insrg will, at its discretion repair or replace product or the defective part of the product free of charge or cause the product or the defective part to be repaired or replaced by an Authorised Insrg Service Agent free of charge.

Insrg reserves the right to substitute defective parts or the Product with parts or product of similar quality, grade and performance where an identical part or product is not available. Parts or products may be replaced by refurbished goods of the same type rather than be repaired.



### Warranty Procedure:

If a fault that is deemed to be covered by warranty occurs, the customer must first contact their retailer and/or builder from which the product was purchased and/or installed.

Any claim must be justified with the following details:

- Proof of Purchase date along with relevant invoice details,
- Full details of the fault, and
- Customer Name, Address and Contact details

The retailer and/or builder will assess the problem and assist Insnrg with the warranty procedure.

The product must be made available to Insnrg or its authorized service agents for full inspection, diagnosis, testing and repair.

If the installation of the product is outside a radius of 30 km (20 miles) from an Authorised Insnrg Service Agent, a service technician travelling fee will apply.

If no defect in materials or workmanship is found, a fee must be paid for Insnrg's costs of service, diagnosis and testing. If such a circumstance you request that Insnrg or Authorised Service Agent complete the non-warrantable repair, a fee will apply for labour and parts used to repair the product.

# EXCLUSIONS

The warranty will not apply where:

- The customer has not complied with Insnrg's terms and conditions of sale
- The product was used in an application for which it wasn't intended
- The product was altered, modified or repaired by any other person than Insnrg or its Authorised Service Agents
- The Product has not been installed, maintained or operated in accordance with Installation and Operating Instructions
- The product has been subject to misuse, abuse, negligence, alteration or accident

Specific warranty exclusions include but are not limited to:

- Normal wear and tear to consumable items such as Gaskets, filter element and Pressure Gauge
- Environmental influences such as flooding, storm, lightning, fire
- Running filtration system without water
- Addition of chemicals in front of pump or directly to skimmer box unless instructed by chemical packaging

Commercial Installations.

Commercial Installation are defined as installations where the pool user pays for the use of the pool either directly or indirectly through hiring or renting of accommodation or membership of a gym, health centre or public pool AND where the pool equipment is operating for more than 16 hours per day.

In such installations the warranty period is limited to 1 year.

## Consequential Damages

Insnrq shall have no liability for incidental or consequential damages or delays caused either directly or indirectly by any malfunction, defect or failure of the equipment.

No person is authorized to make any representation or warranty on behalf of Insnrq without express written consent from Insnrq.









Thanks again for purchasing one of our high performance Cartridge Filter

We know that you will get many years of enjoyment from this product.

Insrng is committed to providing the best quality products and industry best advice and after sales service.

We pride ourselves on developing products that are specifically created for your backyard lifestyle. We are continuously developing new products and ideas to make pool ownership easier and fun.



Should you wish to keep updated with our progress and hear first hand our new products and developments, please feel free to stay in touch by using any or all of the below methods:

**MAIL**

57-59 Nantilla Road,  
Clayton, VIC, 3168

**LANDLINE**

(03) 8578 5633

**WEBSITE**

[www.insnrg.com](http://www.insnrg.com)